

|   |   |   |
|---|---|---|
| <b>International Association Of Certified Practicing Engineers</b>          | <br><b>www.iacpe.com</b><br><b>Knowledge, Certification, and Networking</b> | <b>Page : 1 of 70</b>                             |
|   |   | <b>Rev: 01</b><br><br><b>Rev. 01 – April 2015</b> |
| <b>IACPE</b><br>No 19, Jalan Bilal Mahmood<br>80100 Johor Bahru<br>Malaysia | <b>ELECTRICAL CIRCUITS AND APPLICATIONS</b><br><br><b>CPE LEVEL TWO TRAINING MODULE</b>   |   |

The International Association of Certified Practicing Engineers is providing the introduction to the Training Module for your review.

We believe you should consider joining our Association and becoming a Certified Practicing Engineer. This would be a great option for engineering improvement, certification and networking.

This would help your career by

1. Providing a standard of professional competence in the practicing engineering and management field
2. Identify and recognize those individuals who, by studying and passing an examination, meets the standards of the organization
3. Encourage practicing engineers and management professionals to participate in a continuing program of personal and professional development

**www.IACPE.com**

|  |   |              |
|--|---|--------------|
| <b>International<br/>Association<br/>Of<br/>Certified<br/>Practicing<br/>Engineers</b> | <b>ELECTRICAL CIRCUITS AND<br/>APPLICATIONS</b> | Page 2 of 70 |
|  |   | Rev: 01      |
|  |   | April, 2015  |
| <b>CPE LEVEL TWO<br/>TRAINING MODULE</b>   |   |              |

## TABLE OF CONTENT

### INTRODUCTION

|                       |    |
|-----------------------|----|
| Scope                 | 10 |
| General Consideration | 11 |
| A. Circuit Element    | 11 |
| 1. Passive Element    | 11 |
| 2. Active Element     | 12 |
| B. Circuit Diagram    | 12 |

|            |    |
|------------|----|
| DEFINITION | 16 |
|------------|----|

|               |    |
|---------------|----|
| NOMENCLEATURE | 18 |
|---------------|----|

|               |    |
|---------------|----|
| Greek Letters | 19 |
|---------------|----|

### THEORY

|                                    |    |
|------------------------------------|----|
| A. CIRCUIT LAWS                    | 20 |
| 1) Ohm's Law                       | 20 |
| 2) Kirchhoff's Laws                | 20 |
| 3) Thevenin's Theorem              | 22 |
| 4) Norton's Theorem                | 25 |
| 5) Thevenin and Norton Equivalence | 26 |
| 6) Superposition Theorem           | 27 |

|  |   |              |
|--|---|--------------|
| <b>International<br/>Association<br/>Of<br/>Certified<br/>Practicing<br/>Engineers</b> | <b>ELECTRICAL CIRCUITS AND<br/>APPLICATIONS</b> | Page 3 of 70 |
|  |   | Rev: 01      |
|  |   | April, 2015  |

|  |    |
|--|----|
| 7) Millman's Theorem                     | 29 |
| 8) Reciprocity Theorem                   | 30 |
| <b>B. ELECTRIC CIRCUIT ANALYSIS</b>      |    |
| 1) Linear Circuit Analysis               | 30 |
| a. Time Domain Analysis                  | 31 |
| b. The Branch Current Method             | 34 |
| c. The Mesh Current Method               | 35 |
| d. The Node Voltage Method               | 36 |
| e. Input and Output Resistance           | 37 |
| f. Transfer Resistance                   | 38 |
| g. Network Reduction                     | 39 |
| 2) Nonlinear Circuit Analysis            | 40 |
| a. Graphical                             | 40 |
| b. Sinusoidal Analysis                   | 41 |
| c. Phasor Analysis                       | 45 |
| d. Frequency Response (Laplace) Analysis | 47 |
| <b>C. CIRCUIT MODELING TECHNIQUES</b>    | 53 |
| 1) Source Transformations                | 53 |
| 2) Thevenin and Equivalent Circuit       | 54 |
| 3) Maximum Power Transfer                | 55 |
| <b>D. SAFE CIRCUIT DESIGN</b>            | 55 |
| <b>E. THREE PHASE CIRCUIT DESIGN</b>     | 61 |

|  |   |                     |
|--|---|---------------------|
| <b>International<br/>Association<br/>Of<br/>Certified<br/>Practicing<br/>Engineers</b> | <b>ELECTRICAL CIRCUITS AND<br/>APPLICATIONS</b> | <b>Page 4 of 70</b> |
|  |   | <b>Rev: 01</b>      |
|  |   | <b>April, 2015</b>  |

|  |           |
|--|-----------|
| <b>1) Three Phase Circuit Overview</b> | <b>61</b> |
| <b>2) Wye Connection</b>               | <b>64</b> |
| <b>3) Delta Connection</b>             | <b>65</b> |
| <b>F. CIRCUIT BREAKERS</b>             | <b>66</b> |
| <b>REFERENCES</b>                      |           |

|  |   |              |
|--|---|--------------|
| <b>International<br/>Association<br/>Of<br/>Certified<br/>Practicing<br/>Engineers</b> | <b>ELECTRICAL CIRCUITS AND<br/>APPLICATIONS</b> | Page 5 of 70 |
|  |   | Rev: 01      |
|  |   | April, 2015  |
| <b>CPE LEVEL TWO<br/>TRAINING MODULE</b>   |   |              |

#### **LIST OF TABLE**

|  |           |
|--|-----------|
| <b>Table 1. Representation of Phasor Voltages and Current</b>  | <b>46</b> |
| <b>Table 2. Element Voltage – Current Relationships</b>        | <b>46</b> |
| <b>Table 3. Impedances and Admittances of Circuit Elements</b> | <b>47</b> |
| <b>Table 4. Impedance Relationship for Laplace Analysis</b>    | <b>49</b> |
| <b>Table 5. Laplace Transforms of common functions</b>         | <b>50</b> |

#### **LIST OF FIGURE**

|   |           |
|---|-----------|
| <b>Figure 1. Electrical circuit diagram</b>                                   | <b>13</b> |
| <b>Figure 2. Single device electrical circuit</b>                             | <b>13</b> |
| <b>Figure 3. Example of Circuit Branches</b>                                  | <b>14</b> |
| <b>Figure 4. Example of Nodes in Practical Circuit</b>                        | <b>14</b> |
| <b>Figure 5. Definition of a Loop</b>   | <b>15</b> |
| <b>Figure 6. Definition of a Mesh</b>   | <b>15</b> |
| <b>Figure 7. Closed Loop</b>  | <b>21</b> |
| <b>Figure 8. Kirchhoff Current Law</b>  | <b>22</b> |
| <b>Figure 9. <math>R_{TH}</math> as the input resistance at the terminals</b> | <b>23</b> |

|  |   |              |
|--|---|--------------|
| <b>International<br/>Association<br/>Of<br/>Certified<br/>Practicing<br/>Engineers</b> | <b>ELECTRICAL CIRCUITS AND<br/>APPLICATIONS</b> | Page 6 of 70 |
|  |   | Rev: 01      |
|  |   | April, 2015  |

|   |           |
|---|-----------|
| <b>Figure 10. Linear Circuit with a variable load</b>   | <b>24</b> |
| <b>Figure 11. Linear Circuit</b>  | <b>24</b> |
| <b>Figure 12. <math>R_{TH}</math> and <math>P_{max}</math> graph</b>  | <b>25</b> |
| <b>Figure 13. Complete Circuit</b>  | <b>26</b> |
| <b>Figure 14. The Principle of Superposition</b>  | <b>28</b> |
| <b>Figure 15. Zeroing voltage and current source</b>  | <b>29</b> |
| <b>Figure 16. Circuit with a Single Energy – Storing Element</b>  | <b>31</b> |
| <b>Figure 17. Response of the Circuit in Figure (A)</b>   | <b>32</b> |
| <b>Figure 18. Response of the Circuit Shown in Figure (B)</b>   | <b>33</b> |
| <b>Figure 19. Circuit with two Energy – Storing Elements</b>  | <b>34</b> |
| <b>Figure 20. Electrical Circuit</b>  | <b>36</b> |
| <b>Figure 21. Passive Network</b>   | <b>38</b> |
| <b>Figure 22. Load line</b>   | <b>40</b> |
| <b>Figure 23. Graphical solution equation</b>   | <b>41</b> |
| <b>Figure 24. Transformation of nonlinear circuit of Thevenin</b>   | <b>41</b> |
| <b>Figure 25. A sketch of <math>V_m \sin \omega t</math> : (a) as a fuction of <math>\omega t</math> (b) as a function of t</b> | <b>43</b> |
| <b>Figure 26. Phasor Diagram</b>  | <b>46</b> |

|  |   |              |
|--|---|--------------|
| <b>International<br/>Association<br/>Of<br/>Certified<br/>Practicing<br/>Engineers</b> | <b>ELECTRICAL CIRCUITS AND<br/>APPLICATIONS</b> | Page 7 of 70 |
|  |   | Rev: 01      |
|  |   | April, 2015  |

|  |           |
|--|-----------|
| <b>Figure 27. Transfer Function and representation of a system</b>             | <b>50</b> |
| <b>Figure 28. Poles on the s-plane stability</b>                               | <b>51</b> |
| <b>Figure 29. Source Transformation relationship.</b>                          |           |
| <b>(a) Series Circuit (b) Parallel Circuit</b>                                 | <b>54</b> |
| <b>Figure 30. A simple two – wire electrical power system</b>                  | <b>55</b> |
| <b>Figure 31. A toaster electrical circuit with a conductive metal case</b>    | <b>56</b> |
| <b>Figure 32. Accident touching the wire bare</b>                              | <b>57</b> |
| <b>Figure 33. No danger of shock touching the case of wire</b>                 | <b>57</b> |
| <b>Figure 34. Accidental contact with conductive case</b>                      | <b>58</b> |
| <b>Figure 35. Grounded Case</b>  | <b>59</b> |
| <b>Figure 36. Ground Fault Detection</b>                                       | <b>60</b> |
| <b>Figure 37. Contac accident with metal case</b>                              | <b>60</b> |
| <b>Figure 38. Ground Fault Interrupter system</b>                              | <b>61</b> |
| <b>Figure 39. (a) Single-phase power falls to zero three times each cycle,</b> |           |
| <b>(b) Three-phase power never falls to zero.</b>                              | <b>62</b> |
| <b>Figure 40. Producing a single – phase voltage</b>                           | <b>63</b> |
| <b>Figure 41. The voltages of a three-phase system are 120° out of phase</b>   |           |

|  |   |              |
|--|---|--------------|
| <b>International<br/>Association<br/>Of<br/>Certified<br/>Practicing<br/>Engineers</b> | <b>ELECTRICAL CIRCUITS AND<br/>APPLICATIONS</b> | Page 8 of 70 |
|  |   | Rev: 01      |
|  |   | April, 2015  |

|  |    |
|--|----|
| with each other  | 63 |
| Figure 42. A wye connection is formed by joining one end of each     |    |
| of the windings together   | 64 |
| Figure 43. Line and phase voltages are different in a wye connection | 64 |
| Figure 44. Three-phase delta connection                              | 65 |
| Figure 45. Molded Case Circuit Breaker                               | 66 |
| Figure 46. Cutaway View of Molded Case Circuit Breaker               |    |
| 67   |    |
| Figure 47. Simple Circuit Breaker Control Circuit – Breaker Open     | 69 |



|  |  |                     |
|--|--|---------------------|
| <b>International<br/>Association<br/>Of<br/>Certified<br/>Practicing<br/>Engineers</b> | <b>ELECTRICAL CIRCUIT AND<br/>APPLICATION<br/><br/>CPE LEVEL<br/>TRAINING MODULE</b> | <b>Page 9 of 70</b> |
|  |  | <b>Rev: 01</b>      |
|  |  | <b>April, 2015</b>  |

## **INTRODUCTION**

### **Scope**

An electrical circuit or electrical network is an array of interconnected elements wired so as to be capable of conducting current. Each electrical circuit has at least four basic parts, there are a source of electromotive force, conductors, load or loads, and some means of control. The fundamental two-terminal elements of an electrical electrical circuit are the resistor, the capacitor, the inductor, the voltage source and the current source.

Electrical circuit is an important and perhaps the oldest branch of electrical engineering. A circuit is an interconnection of electrical elements. There are two aspects to circuit theory, analysis and design. Circuit analysis involves in different elements of the circuit, given the values of the sources or excitation. On the other branch, circuit design focuses on the design of circuit that exhibit a certain pre-specified voltage or current characteristic at one or more.

This training module provides an overview one of the electrical circuit with the basic laws of electrical circuit analysis, the basic circuit element and the application. This module will help develop the basic of generation, transmission and distribution of electricity.

|  |   |               |
|--|---|---------------|
| <b>International<br/>Association<br/>Of<br/>Certified<br/>Practicing<br/>Engineers</b> | <b>ELECTRICAL CIRCUIT AND<br/>APPLICATION</b><br><br><b>CPE LEVEL<br/>TRAINING MODULE</b> | Page 10 of 70 |
|  |   | Rev: 01       |
|  |   | April, 2015   |

## General Considerations

### A. Circuit Elements

An electric circuit is simply an interconnection of elements there are two types of elements found in electric circuits: passive elements and active elements. An active element is capable of generating energy while a passive element is not. Our aim in this section is to gain familiarity with some important passive and active elements.

#### 1) Passive element

In the linear and nonlinear circuit, there are three passive circuit elements are resistors or resistance (R), inductors or inductance (L), and capacitors or capacitance (C). A passive circuit element is incapable of delivering power to a circuit. However, inductors store energy in the form of current and capacitors store energy in the form of voltage so they can release energy previously stored back to the circuit.

##### a) Resistance

All electrical devices that consume energy must have a resistor (also called a resistance) in their circuit model. Inductors and capacitors may store energy but over time return that energy to the source or to another circuit element. Resistance is a measure of how hard it is for charges to move in the system.

##### b) Inductance

The circuit element that stores energy in a magnetic field is an inductor (also called Inductance). With time-variable current, the energy is generally stored during some parts of the cycle and then returned to the source during others. When the inductance is removed from the source, the magnetic field will collapse, in order the words, no energy is stored without a connected source.

##### c) Capacitance

The circuit element that stores energy in an electric field is a capacitor (also called capacitance). When the voltage is variable over a cycle, energy will be stored during one part of the cycle and returned in the next. While an inductance cannot retain energy after removal of the source because the magnetic field collapses, the capacitor retains the charge and the electric field can remain after the source is removed.

|  |   |               |
|--|---|---------------|
| <b>International<br/>Association<br/>Of<br/>Certified<br/>Practicing<br/>Engineers</b> | <b>ELECTRICAL CIRCUIT AND<br/>APPLICATION</b><br><br><b>CPE LEVEL<br/>TRAINING MODULE</b> | Page 11 of 70 |
|  |   | Rev: 01       |
|  |   | April, 2015   |

## 2) Active element

The most important active elements are voltage or current sources that generally deliver power to the circuit connected to them. There are two kinds of sources: independent and dependent sources. An ideal independent source is an active element that provides a specified voltage or current that is completely independent of other circuit variables. An ideal dependent (or controlled) source is an active element in which the source quantity is controlled by another voltage or current. It should be noted that an ideal voltage source (dependent or independent) will produce any current required to ensure that the terminal voltage is as stated; whereas an ideal current source will produce the necessary voltage to ensure the stated current flow.

### a) Voltage

Voltage is the force created by the separation of charges. Kind of like when two opposite poles of a magnet are put close together, but are separated by a short distance. A force tries to pull them together, but are separated by a short distance. A force tries to pull them together. When there are more negative charges on the inside of the membrane of a cell, there is a force driving positive charges inward to neutralize them. The unit of voltage is the volt and it is represented by the symbol V. voltage is also called “potential” or “potential difference”.

### b) Current

Current is defined as the time rate of change of charge passing through a predetermined area. The symbol for current is (I). The basic measurement for current is the ampere (A). The name of the unit is a tribute to the French scientist Andre Marie Ampere. To produce current, the electrons must be moved by a potential difference. There are two type of Electric current, direct current (DC) and alternating current (AC). DC is a current that remains constant with time. AC is a current that varies sinusoidally with time.

## B. Circuit Diagram

Every circuit diagram can be constructed in a variety of ways may look different but are in fact identical. The diagram presented in a problem may not suggest the best of several methods of solution. Consequently, a diagram should be examined before a solution is started and redrawn if necessary to show clearly how the elements are interconnected.

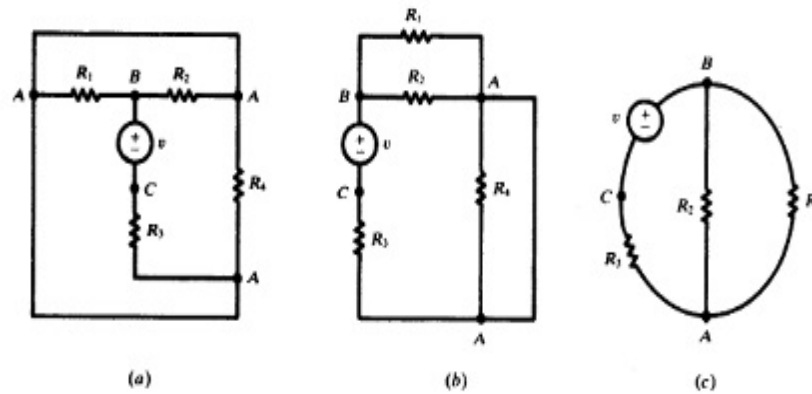

**Figure 1. Electrical circuit diagram**

An electrical device is represented by a circuit diagram or network constructed from series and parallel arrangement of two-terminal elements. The analysis of the circuit diagram predicts the performance of the actual device. A two terminal element in general form is shown in Figure 2, with a single device represented by the rectangular symbol and two perfectly conducting leads ending at connecting points A and B.

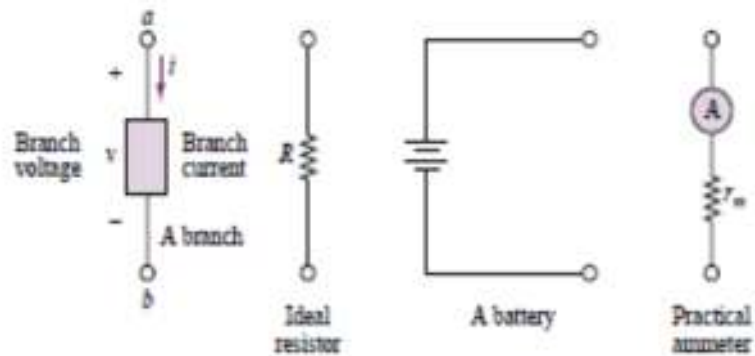

**Figure 2. Single device electrical circuit**

**a) Branch**

A branch is any portion of circuit with two terminals connected to it. A branch may consist of one or more circuit elements (Figure 3). In practice, any circuit element with two terminals connected to it is a branch.

|  |   |                      |
|--|---|----------------------|
| <b>International<br/>Association<br/>Of<br/>Certified<br/>Practicing<br/>Engineers</b> | <b>ELECTRICAL CIRCUIT AND<br/>APPLICATION</b> | <b>Page 13 of 70</b> |
|  |   | <b>Rev: 01</b>       |
|  | <b>CPE LEVEL<br/>TRAINING MODULE</b>          | <b>April, 2015</b>   |



**Figure 3. Example of Circuit Branches**

### b) Node

A node is the junction of two or more branches (one often refers to the junction of only two branches as a *trivial node*). Figure 4 illustrates the concept. In effect, any connection that can be accomplished by soldering various terminals together is a node. It is very important to identify nodes properly in the analysis of electrical networks.

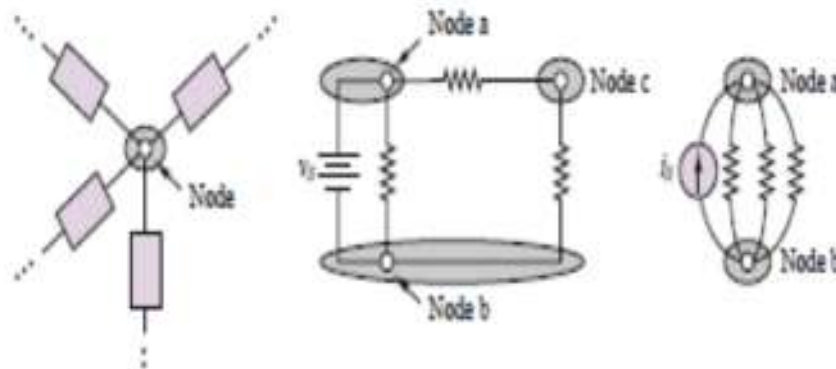

**Figure 4. Example of Nodes in Practical Circuit**

### c) Loop

A loop is any closed connection of branches. Various loop configurations are illustrated in Figure 5.

|   |   |               |
|---|---|---------------|
| International Association<br>Of<br>Certified<br>Practicing<br>Engineers | ELECTRICAL CIRCUIT AND<br>APPLICATION<br><br>CPE LEVEL<br>TRAINING MODULE | Page 14 of 70 |
|   |   | Rev: 01       |
|   |   | April, 2015   |

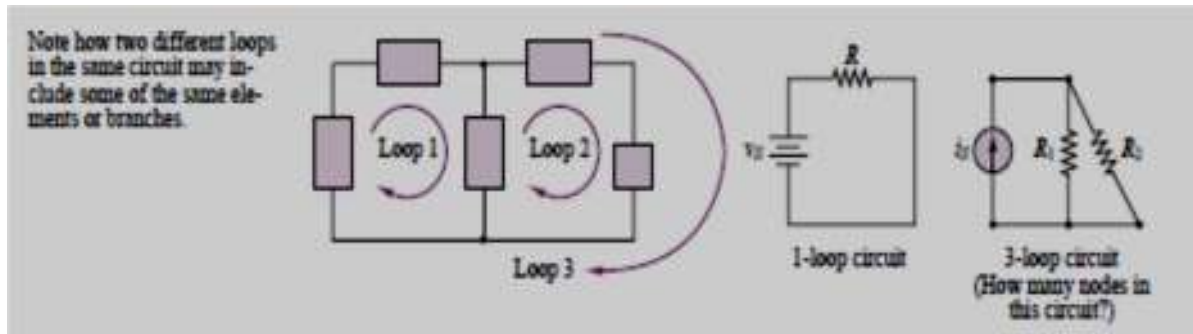

Figure 5. Definition of a Loop

#### d) Mesh

A mesh is a loop that does not contain other loops. Meshes are an important aid to certain analysis methods. In Figure 6, the circuit with loops 1, 2, and 3 consists of two meshes: loops 1 and 2 are meshes, but loop 3 is not a mesh, because it encircles both loops 1 and 2. The one-loop circuit of Figure 6 is also a one-mesh circuit. Figure 6 illustrates how meshes are simpler to visualize in complex networks than loops are.

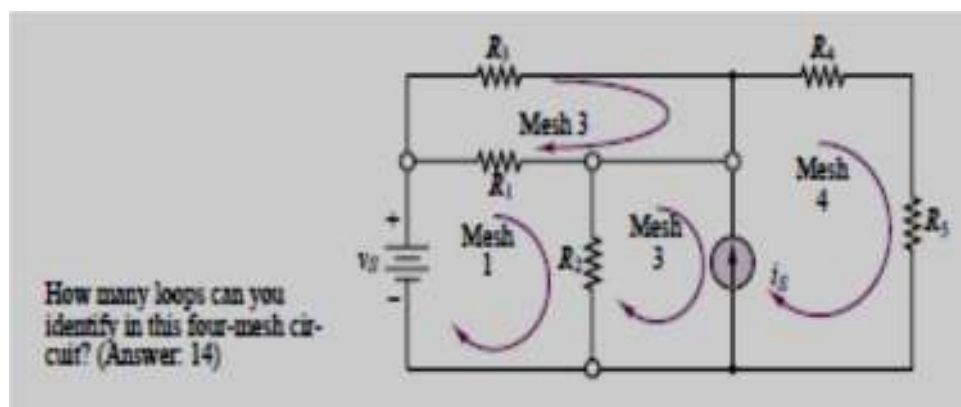

Figure 6. Definition of a Mesh

|  |  |                      |
|--|--|----------------------|
| <b>International<br/>Association<br/>Of<br/>Certified<br/>Practicing<br/>Engineers</b> | <b>ELECTRICAL CIRCUIT AND<br/>APPLICATION<br/><br/>CPE LEVEL<br/>TRAINING MODULE</b> | <b>Page 15 of 70</b> |
|  |  | <b>Rev: 01</b>       |
|  |  | <b>April, 2015</b>   |

## **DEFINITIONS**

Active element – A circuit element that generates power

Capacitor – A two-terminal electrical element that satisfies a prescribed algebraic relationship in the charge – voltage ( $q - V$ ) plane.

Controlled source – A current or voltage branch element whose value depends on a branch current or voltage determined elsewhere in the network.

Current – the time rate of change of net charge passing through an arbitrary cross section of an electrical element.

Distributed element – A circuit element whose feature size is comparable to, or significantly larger than, the wavelength of applied energy.

Electrical circuit – An array interconnected elements wired so as to be capable of conducting current.

Inductor – A two-terminal electrical element that satisfies a prescribed algebraic relationship in the flux current ( $\phi - I$ ) plane.

Mesh Analysis – a method that is used to solve planar circuits for the currents (and indirectly the voltages) at any place in the circuit.

Node - is the point of connection between two or more branches.

Loop - is any closed path in a circuit.

Passive element – A circuit element whose feature size is significantly smaller than the wavelength of applied energy.

Power – The time rate of change of energy applied to an electrical element.

Resistor – A two-terminal electrical element that satisfies a prescribed algebraic relationship in the voltage – current ( $V - I$ ) plane.

|  |  |                      |
|--|--|----------------------|
| <b>International<br/>Association<br/>Of<br/>Certified<br/>Practicing<br/>Engineers</b> | <b>ELECTRICAL CIRCUIT AND<br/>APPLICATION<br/><br/>CPE LEVEL<br/>TRAINING MODULE</b> | <b>Page 16 of 70</b> |
|  |  | <b>Rev: 01</b>       |
|  |  | <b>April, 2015</b>   |

Voltage – The energy applied to an element per unit of charge transported through the element.



|  |  |                      |
|--|--|----------------------|
| <b>International<br/>Association<br/>Of<br/>Certified<br/>Practicing<br/>Engineers</b> | <b>ELECTRICAL CIRCUIT AND<br/>APPLICATION<br/><br/>CPE LEVEL<br/>TRAINING MODULE</b> | <b>Page 17 of 70</b> |
|  |  | <b>Rev: 01</b>       |
|  |  | <b>April, 2015</b>   |

## **NOMENCLATURE**

|                 |  |
|-----------------|--|
| A               | : Area of the cross section, m <sup>2</sup>                          |
| C               | : Capacitance, F   |
| E               | : Electric field strength, V/m                                       |
| f               | : Frequency, Hz  |
| I               | : Current, Ampere  |
| I <sub>oc</sub> | : Open circuit current, Ampere                                       |
| K               | : Constant of proportionality, Coulomb <sup>2</sup> /Nm <sup>2</sup> |
| L               | : Inductance, H  |
| l               | : Length, m  |
| M               | : Mutual Inductance, H   |
| N               | : Total number of nodes  |
| P               | : Power rating, W  |
| r               | : Distance between two particles, m                                  |
| R               | : Resistance, Ω  |
| R <sub>TH</sub> | : Thevenin Resistance, Ω   |
| t               | : Time, seconds  |
| T               | : Period of sinusoid, 1/second                                       |
| v               | : velocity, m/s  |
| V               | : Voltage, Volt  |
| V <sub>oc</sub> | : Open circuit voltage, Volt   |
| Z               | : Impedance, Ω   |

|  |  |                      |
|--|--|----------------------|
| <b>International<br/>Association<br/>Of<br/>Certified<br/>Practicing<br/>Engineers</b> | <b>ELECTRICAL CIRCUIT AND<br/>APPLICATION<br/><br/>CPE LEVEL<br/>TRAINING MODULE</b> | <b>Page 18 of 70</b> |
|  |  | <b>Rev: 01</b>       |
|  |  | <b>April, 2015</b>   |

### **Greek Letters**

- $\rho$  : Resistivity of the material, ohm-meters
- $\theta$  : Angle
- $\phi$  : Phase
- $\mathcal{L}$  : Laplace transform