

<p>KLM Technology Group</p> <p>Practical Engineering Guidelines for Processing Plant Solutions</p>	<div style="text-align: center;">  <p>Engineering Solutions</p> <p>www.klmtechgroup.com</p> </div>	<p>Page : 1 of 97</p> <hr/> <p>Rev: 01</p> <hr/> <p>Rev 01 – May 2015 Rev 02 – Feb 2020</p>
<p>KLM Technology Group P. O. Box 281 Bandar Johor Bahru, 80000 Johor Bahru, Johor, West Malaysia</p>	<div style="text-align: center;"> <p>Kolmetz Handbook Of Process Equipment Design</p> <p>PLATE HEAT EXCHANGER SELECTION, SIZING AND TROUBLESHOOTING</p> <p>(ENGINEERING DESIGN GUIDELINES)</p> </div>	<p>Co Authors</p> <p>Rev 01 – Mela Widiawati Rev 02 – Apriliana Dwijayanti</p> <hr/> <p>Author / Editor</p> <p>Karl Kolmetz</p>

TABLE OF CONTENTS

INTRODUCTION.....	6
Scope	6
General Consideration.....	7
The Frame.....	9
The Plates	12
The Gaskets.....	12
Profile and Structure	13
Plate Heat Exchanger Compare with Others	21
 DEFINITION.....	 24
 NOMENCLATURE.....	 26

KLM Technology Group Practical Engineering Guidelines for Processing Plant Solutions www.klmtechgroup.com	Kolmetz Handbook Of Process Equipment Design PLATE HEAT EXCHANGER SELECTION, SIZING AND TROUBLESHOOTING (ENGINEERING DESIGN GUIDELINES)	Page 2 of 97
		Rev: 02
		Rev 02 – Feb 2020

Plate Heat Exchanger Design.....	28
Plate Heat Exchanger Construction	30
Plate heat exchanger components	30
Brazed plate heat exchangers	31
Working Principle	31
Evaluating plate heat exchangers	31
Flow distribution and heat transfer equation	32
 THEORY	 32
Heat Exchangers.....	32
Classification of Heat Exchangers by Flow Configuration.....	34
Classification of Heat Exchangers by Construction.....	37
Materials	54
Flow Arrangements	56
Estimation of the Temperature Correction Factor	57
Heat transfer coefficient.....	59
Overall Heat Transfer Coefficient	61
LMTD Method	64
Pressure Drop	65
Applications	66
Maximum Pressure and Temperature Ratings	67
Size Limitations.....	67
Fouling Factors	67
Condensing	68
Pressure Drop of Condensing Vapor	69

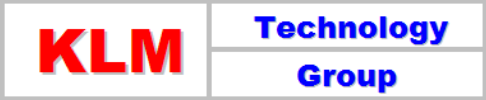
These design guideline are believed to be as accurate as possible, but are very general and not for specific design cases. They were designed for engineers to do preliminary designs and process specification sheets. The final design must always be guaranteed for the service selected by the manufacturing vendor, but these guidelines will greatly reduce the amount of up front engineering hours that are required to develop the final design. The guidelines are a training tool for young engineers or a resource for engineers with experience.

This document is entrusted to the recipient personally, but the copyright remains with us. It must not be copied, reproduced or in any way communicated or made accessible to third parties without our written consent.

KLM Technology Group Practical Engineering Guidelines for Processing Plant Solutions www.klmtechgroup.com	Kolmetz Handbook Of Process Equipment Design PLATE HEAT EXCHANGER SELECTION, SIZING AND TROUBLESHOOTING (ENGINEERING DESIGN GUIDELINES)	Page 3 of 97
		Rev: 02
		Rev 02 – Feb 2020

Gas Cooling	69
Evaporating	69
Laminar Flow	70
Comparing Plate and Tubular Exchangers	71
Plate Fin Heat Exchangers	74
Design of Compact Plate Fin Heat Exchanger	79
Other Forms of Plate Heat Exchangers (Marriot)	82
APPLICATION	85
Example 1 : Investigate the use of a gasketed plate heat exchanger	85
Example 2 : Plate Fin Heat Exchanger Design	91
REFERENCES	97

These design guideline are believed to be as accurate as possible, but are very general and not for specific design cases. They were designed for engineers to do preliminary designs and process specification sheets. The final design must always be guaranteed for the service selected by the manufacturing vendor, but these guidelines will greatly reduce the amount of up front engineering hours that are required to develop the final design. The guidelines are a training tool for young engineers or a resource for engineers with experience.

This document is entrusted to the recipient personally, but the copyright remains with us. It must not be copied, reproduced or in any way communicated or made accessible to third parties without our written consent.

KLM Technology Group Practical Engineering Guidelines for Processing Plant Solutions www.klmtechgroup.com	Kolmetz Handbook Of Process Equipment Design PLATE HEAT EXCHANGER SELECTION, SIZING AND TROUBLESHOOTING (ENGINEERING DESIGN GUIDELINES)	Page 4 of 97
		Rev: 02
		Rev 02 – Feb 2020

LIST OF FIGURE

Figure 1. Plate Heat Exchanger.....	10
Figure 2. Two Section PHE with Connector Plate	12
Figure 3. Plate and Frame Heat Exchanger.....	14
Figure 4. The Process and Service Fluid Flow Counter Currently Between The Plates.....	15
Figure 5. Double Gasketed Prevent Fluids Mixing	17
Figure 6. Countercurrent Flow	34
Figure 7. Cocurrent Flow	35
Figure 8. Cross Flow.....	36
Figure 9. Hybrids	37
Figure 10. Heat Exchanger Classifications.....	38
Figure 11. Plate Exchanger Classification.....	41
Figure 12. Plate Fin Exchanger	42
Figure 13. Spiral Heat Exchanger	44
Figure 14. Sprial Heat Exchanger flow arrangement.....	46
Figure 15. Shell and Tube Exchanger.....	53
Figure 16. Plate and Frame Exchanger	54
Figure 17. Plate Heat Exchanger Flow Arrangements	58
Figure 18. Log Mean Temperature Correction Factor for Plate Heat Exchangers.	59
Figure 19. Effect of Velocity and Turbulence.....	68

These design guideline are believed to be as accurate as possible, but are very general and not for specific design cases. They were designed for engineers to do preliminary designs and process specification sheets. The final design must always be guaranteed for the service selected by the manufacturing vendor, but these guidelines will greatly reduce the amount of up front engineering hours that are required to develop the final design. The guidelines are a training tool for young engineers or a resource for engineers with experience.

This document is entrusted to the recipient personally, but the copyright remains with us. It must not be copied, reproduced or in any way communicated or made accessible to third parties without our written consent.

KLM Technology Group Practical Engineering Guidelines for Processing Plant Solutions www.klmtechgroup.com	Kolmetz Handbook Of Process Equipment Design PLATE HEAT EXCHANGER SELECTION, SIZING AND TROUBLESHOOTING (ENGINEERING DESIGN GUIDELINES)	Page 5 of 97
		Rev: 02
		Rev 02 – Feb 2020

Figure 20. Plate fin heat exchanger assembly and details Side bars Plates..... 75

Figure 21. Types of plate fin surfaces (a) plain rectangular, (b) plain trapezoidal, (c) wavy (d) serrated or offset strip fin (e) louvered and (f) perforated 78

LIST OF TABLE

Table 1. Construction Features..... 11

Table 2. Typical Fouling Factors for PHEs..... 19

Table 3. Comparison Between PHE and Shell and Tube Heat Exchanger 20

Table 4. Characteristics of Some Gaskets Materials..... 29

Table 5. Typical Gasket Materials for Plate Heat Exchangers..... 56

Table 6. Shape factors S for several configurations 62

Table 7. Typical Values of Fouling Coefficient and Resistances 86

These design guideline are believed to be as accurate as possible, but are very general and not for specific design cases. They were designed for engineers to do preliminary designs and process specification sheets. The final design must always be guaranteed for the service selected by the manufacturing vendor, but these guidelines will greatly reduce the amount of up front engineering hours that are required to develop the final design. The guidelines are a training tool for young engineers or a resource for engineers with experience.

This document is entrusted to the recipient personally, but the copyright remains with us. It must not be copied, reproduced or in any way communicated or made accessible to third parties without our written consent.

KLM Technology Group Practical Engineering Guidelines for Processing Plant Solutions www.klmtechgroup.com	Kolmetz Handbook Of Process Equipment Design PLATE HEAT EXCHANGER SELECTION, SIZING AND TROUBLESHOOTING (ENGINEERING DESIGN GUIDELINES)	Page 6 of 97
		Rev: 02
		Rev 02 – Feb 2020

INTRODUCTION

Scope

This design guideline covers the selection and sizing method for plate heat exchangers which are commonly used in typical industrial processes. It helps engineers, operations and maintenance personnel to understand the basic design of different types of heat exchangers, and increases their knowledge in selection and sizing. A heat exchanger is a device for heat transfer from one medium to another. The personnel needs to understand the terminology of the heat transfer equipment in order to properly design, specify, evaluate bids, and check drawings for this equipment.

Heat transfer is one of the most important, as well as the most applied process, in chemical and petrochemical plants. Economics of plant operation often are controlled by the effectiveness of the use and recovery of heat or cold (refrigeration). The service functions of steam, power, refrigeration supply, and the like are dictated by how these service or utilities are used within the process to produce an efficient conversion and recovery of heat.

The basic plate heat exchanger consist of a series of thin, corrugated plates that are gasketed or welded together (or any combination of these) depending on the liquids passing through and on whether it is practical to be able to subsequently separates the plates, for whatever reason.

The plates are then compressed together in a rigid frame to create an arrangement of parallel flow channels. One fluid travels in the odd numbered channels, the other in the even channels. All plate heat exchangers look similar from the outside. The differences lie inside, in the details of plate design and the sealing technologies used.

The basic concept of a heat exchanger is based on the promise that the loss of heat on the high temperature side is exactly the same as the heat gained in the low temperature side after the heat and mass flows through the heat exchanger. Heat exchanger simply exchanges the heat between those two sides; as a result, it is decreasing the temperature of higher temperature side and increasing the temperature of lower

These design guideline are believed to be as accurate as possible, but are very general and not for specific design cases. They were designed for engineers to do preliminary designs and process specification sheets. The final design must always be guaranteed for the service selected by the manufacturing vendor, but these guidelines will greatly reduce the amount of up front engineering hours that are required to develop the final design. The guidelines are a training tool for young engineers or a resource for engineers with experience.

This document is entrusted to the recipient personally, but the copyright remains with us. It must not be copied, reproduced or in any way communicated or made accessible to third parties without our written consent.

KLM Technology Group Practical Engineering Guidelines for Processing Plant Solutions www.klmtechgroup.com	Kolmetz Handbook Of Process Equipment Design PLATE HEAT EXCHANGER SELECTION, SIZING AND TROUBLESHOOTING (ENGINEERING DESIGN GUIDELINES)	Page 7 of 97
		Rev: 02
		Rev 02 – Feb 2020

temperature side. But designing heat exchanger might be a challenge; it needs iteration for manual calculation. Hence, a guideline to properly select and sizing is needed.

An innovative type of heat exchanger that has found widespread use is the plate and frame (or just plate) heat exchanger, which consists of a series of plates with corrugated flat flow passages. The hot and cold fluids flow in alternate passages, and thus each cold fluid stream is surrounded by two hot fluid streams, resulting in very effective heat transfer. Also, plate heat exchangers can grow with increasing demand for heat transfer by simply mounting more plates. They are well suited for liquid to liquid heat exchange applications, provided that the hot and cold fluid streams are at about the same pressure.

General Consideration

Plate type heat exchangers (PHE) consist of a number of parallel flow channels, formed by adjacent metal plates that are either welded or separated by gasket material around the perimeter of each plate. The plates can be formed from a variety of metals, but typically are made of stainless steel. The manufacturing process presses the plates into a corrugated shape that is different for each plate type and is proprietary to each manufacturer.

The corrugations (sometimes called ribs or chevrons) both increase the mixing of the flow stream and add strength and support to the plate. The flow channel width between adjacent plates ranges from 0.05 to 0.25 in. (1.27 to 6.35 mm) and the ribs of adjacent plates have contact point with each other at regular intervals. PHEs can be designed for true counter flow because the hot and cold flow streams pass through adjacent channels over the entire length of the exchanger.

This design allows closer approach temperatures than are possible with conventional shell and tube exchangers. The assembly of PHE facilities mechanical cleaning and allows the additional or removal of plates to increase or decrease the heat transfer surface area of the exchanger.

These design guideline are believed to be as accurate as possible, but are very general and not for specific design cases. They were designed for engineers to do preliminary designs and process specification sheets. The final design must always be guaranteed for the service selected by the manufacturing vendor, but these guidelines will greatly reduce the amount of up front engineering hours that are required to develop the final design. The guidelines are a training tool for young engineers or a resource for engineers with experience.

This document is entrusted to the recipient personally, but the copyright remains with us. It must not be copied, reproduced or in any way communicated or made accessible to third parties without our written consent.

KLM Technology Group Practical Engineering Guidelines for Processing Plant Solutions www.klmtechgroup.com	Kolmetz Handbook Of Process Equipment Design PLATE HEAT EXCHANGER SELECTION, SIZING AND TROUBLESHOOTING (ENGINEERING DESIGN GUIDELINES)	Page 8 of 97
		Rev: 02
		Rev 02 – Feb 2020

The main advantages of PHE are their compact size and high heat transfer effectiveness that allow reduced number of units, smaller spaces and, for offshore platforms, and reduced weight. They are especially attractive in cost when the equivalent shell and tube exchanger would require in alloy shell or tubes. The minimum recommended construction material for all types of PHEs and welded PHEs is type 304 stainless steel.

PHEs are presently operating in such liquid-liquid services as heat recovery loops, chemical process coolers and heaters, oil platform applications, and seawater cooling. Partially welded PHEs make good applications in product coolers using cooling water.

The plate and frame heat exchanger is not specifically considered, because steady state design follows standard contraflow or parallel flow procedures. It is only necessary to source sets of heat transfer and flow friction correlations before proceeding.

Plate and frame designs can be similar in flow arrangement to plate fin designs, but there is restriction on the piping manifold geometry. Optimization may proceed in a similar way as for compact plate fin heat exchangers, but is likely to be less comprehensive until universal correlations for the best plate panel corrugations become available.

Significant features are composed of metal formed thin plates separated by gaskets. Compact, easy to clean. Application best suited are viscous fluids, corrosive fluids, slurries, high heat transfer. Limitation are not well suited for boiling or condensing; limit 35-500°F by gaskets. Used for liquid-liquid only; not gas-gas. Approximate relative cost in carbon steel construction 0.8 – 1.5.

Inlet and return headering for plate and frame designs, and the same arrangement for plate fin designs, may add a phase shift to the outlet transient response following and inlet disturbance.

Plate type exchangers consist of a number of parallel flow channels, formed by adjacent metal plates that are either welded or separated by gasket material around the

These design guideline are believed to be as accurate as possible, but are very general and not for specific design cases. They were designed for engineers to do preliminary designs and process specification sheets. The final design must always be guaranteed for the service selected by the manufacturing vendor, but these guidelines will greatly reduce the amount of up front engineering hours that are required to develop the final design. The guidelines are a training tool for young engineers or a resource for engineers with experience.

This document is entrusted to the recipient personally, but the copyright remains with us. It must not be copied, reproduced or in any way communicated or made accessible to third parties without our written consent.

KLM Technology Group Practical Engineering Guidelines for Processing Plant Solutions www.klmtechgroup.com	Kolmetz Handbook Of Process Equipment Design PLATE HEAT EXCHANGER SELECTION, SIZING AND TROUBLESHOOTING (ENGINEERING DESIGN GUIDELINES)	Page 9 of 97
		Rev: 02
		Rev 02 – Feb 2020

perimeter of each plate. The plates can be formed from a variety of metals, but typically are made of stainless steel.

The manufacturing process presses the plates into a corrugated shape that is different for each plate type and is proprietary to each manufacturer. The corrugation (sometimes called ribs or chevrons) both increase the mixing of the flow stream and add strength and support to the plate.

The Frame

The plate heat exchanger, as shown in Figure 1, consists of a stationary head and end support connected by a top carrying bar and bottom guide rail. These form a rigid frame, which supports the plates and moveable follower. In most units, plates are securely compressed between the head and follower by means of tie bars on either side of the exchanger.

In a few models, central tightening spindles working against a reinforced end support are used for compression. When PHEs are opened, the follower moves easily along the top bar with the aid of a bearing supported roller, to allow full access to each individual plate. With the expectation of some sanitary models, which are clad with stainless steel, PHE frames are fabricated of carbon steel and finished in chemical resistant epoxy paint.

Frame ports accept bushings of stainless steel or alternative metals, which with various types of flanged or sanitary connections, from the inlet and outlet nozzles. By using intermediate connector plates as shown in Figure 2, units can be divided into separate sections to accommodate multiple duties within a single frame.

These design guideline are believed to be as accurate as possible, but are very general and not for specific design cases. They were designed for engineers to do preliminary designs and process specification sheets. The final design must always be guaranteed for the service selected by the manufacturing vendor, but these guidelines will greatly reduce the amount of up front engineering hours that are required to develop the final design. The guidelines are a training tool for young engineers or a resource for engineers with experience.

This document is entrusted to the recipient personally, but the copyright remains with us. It must not be copied, reproduced or in any way communicated or made accessible to third parties without our written consent.

KLM Technology Group Practical Engineering Guidelines for Processing Plant Solutions www.klmtechgroup.com	Kolmetz Handbook Of Process Equipment Design PLATE HEAT EXCHANGER SELECTION, SIZING AND TROUBLESHOOTING (ENGINEERING DESIGN GUIDELINES)	Page 10 of 97
		Rev: 02
		Rev 02 – Feb 2020

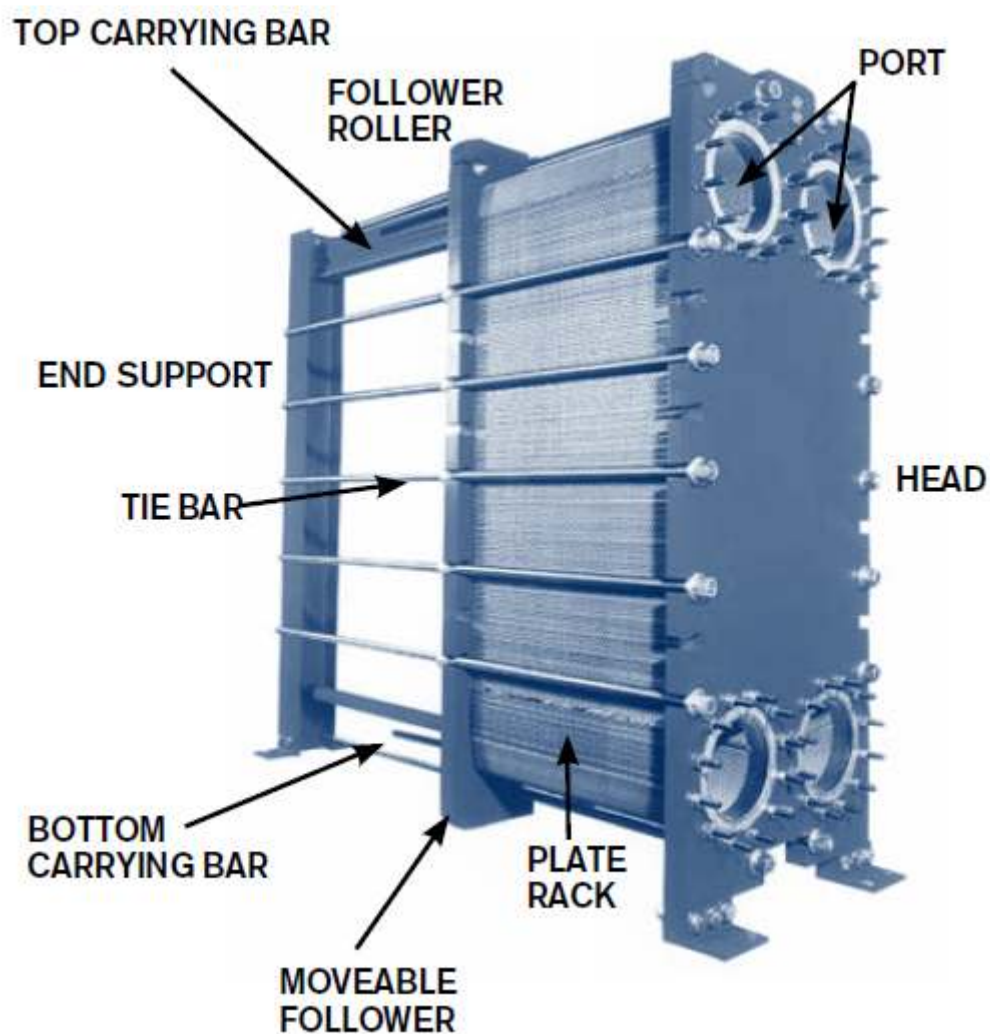

Figure 1. Plate Heat Exchanger

Frames are usually free standing; for smaller units, they are attached to structural steel work. Salient constructional features of PHE and the resulting advantages and benefits are given in Table 1.

These design guideline are believed to be as accurate as possible, but are very general and not for specific design cases. They were designed for engineers to do preliminary designs and process specification sheets. The final design must always be guaranteed for the service selected by the manufacturing vendor, but these guidelines will greatly reduce the amount of up front engineering hours that are required to develop the final design. The guidelines are a training tool for young engineers or a resource for engineers with experience.

This document is entrusted to the recipient personally, but the copyright remains with us. It must not be copied, reproduced or in any way communicated or made accessible to third parties without our written consent.

KLM Technology Group Practical Engineering Guidelines for Processing Plant Solutions www.klmtechgroup.com	Kolmetz Handbook Of Process Equipment Design PLATE HEAT EXCHANGER SELECTION, SIZING AND TROUBLESHOOTING (ENGINEERING DESIGN GUIDELINES)	Page 11 of 97
		Rev: 02
		Rev 02 – Feb 2020

Table 1. Construction Features

Feature	Advantage	Benefit
PHE concept	Efficient heat transfer, low weight	Reduced capital cost, smaller foundations (lower investment cost)
Modular construction	Flexibility	Easy to modify for altered duties
Fixed frame and movable pressure	Easily accessible heat-transfer area	Reduced shutdown time, i.e., lower plates maintenance and operating costs
Metallic contact between plates	Minimized vibrations	Longer lifetime; great reliability
Bearing boxes on tightening bolts	Reduced friction	Easy opening and closing, reduced maintenance
One-step plate pressing	High dimensional tolerances	Improved performance
Glue-free gaskets	Simplified regasketing while still in frame	Reduced shut-down time, reduced maintenance costs
Two-component oven-cured epoxy on glued gaskets	Superior bonding	Greater reliability

These design guideline are believed to be as accurate as possible, but are very general and not for specific design cases. They were designed for engineers to do preliminary designs and process specification sheets. The final design must always be guaranteed for the service selected by the manufacturing vendor, but these guidelines will greatly reduce the amount of up front engineering hours that are required to develop the final design. The guidelines are a training tool for young engineers or a resource for engineers with experience.

This document is entrusted to the recipient personally, but the copyright remains with us. It must not be copied, reproduced or in any way communicated or made accessible to third parties without our written consent.

KLM Technology Group Practical Engineering Guidelines for Processing Plant Solutions www.klmtechgroup.com	Kolmetz Handbook Of Process Equipment Design PLATE HEAT EXCHANGER SELECTION, SIZING AND TROUBLESHOOTING (ENGINEERING DESIGN GUIDELINES)	Page 12 of 97
		Rev: 02
		Rev 02 – Feb 2020

The Plates

The closely spaced metal heat transfer plates have through or corrugations, which induced turbulence to the liquids flowing as a thin stream between the plates. The plates have corner ports, which in the complete plate pack form a manifold for even fluid distribution to the individual plate passage.

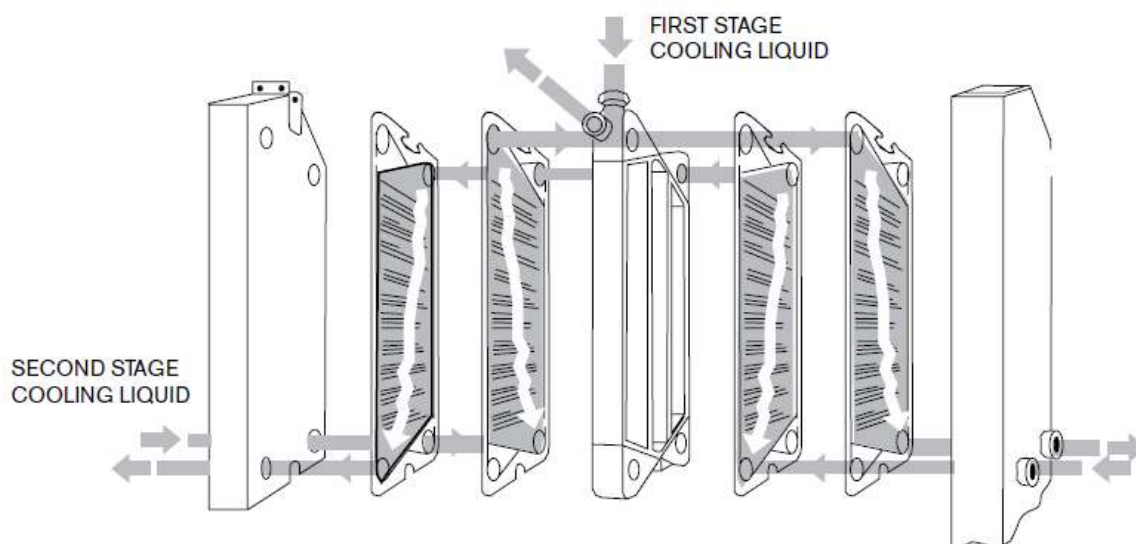

Figure 2. Two Section PHE with Connector Plate

The Gaskets

The seal between the plates is established by a peripheral gasket which also separates the thru port and flow areas with a double barrier. The interspace is vented to atmosphere to prevent cross-contamination in the event of leakage.

Gasketed plate and frame exchanger, in this type the plates are sandwiched together by an outside frame with tie rods that provide uniform sealing of the plate gaskets. The plates are 0.02 to 0.04 in (0.6 to 1 mm) thick. The size of the individual plates ranges

These design guideline are believed to be as accurate as possible, but are very general and not for specific design cases. They were designed for engineers to do preliminary designs and process specification sheets. The final design must always be guaranteed for the service selected by the manufacturing vendor, but these guidelines will greatly reduce the amount of up front engineering hours that are required to develop the final design. The guidelines are a training tool for young engineers or a resource for engineers with experience.

This document is entrusted to the recipient personally, but the copyright remains with us. It must not be copied, reproduced or in any way communicated or made accessible to third parties without our written consent.

KLM Technology Group Practical Engineering Guidelines for Processing Plant Solutions www.klmtechgroup.com	Kolmetz Handbook Of Process Equipment Design PLATE HEAT EXCHANGER SELECTION, SIZING AND TROUBLESHOOTING (ENGINEERING DESIGN GUIDELINES)	Page 13 of 97
		Rev: 02
		Rev 02 – Feb 2020

from a minimum of approximately 0.5 ft x 1.5 ft (0.15 m x 0.46 m) to as large as 4 ft x 10 ft (1.220 m x 3.05 m). Plate and frame exchangers have heat transfer surface areas ranging from 5 to 13,000 ft² (0.5 to 1210 m²).

The maximum temperature and pressure limits on a gasketed PHE are approximately 450°F and 350 psia [230°C and 2400 kPa(a)].

Profile and Structure

A typical plate and frame heat exchanger (sometimes referred to as a gasketed plate heat exchanger) is shown in an exploded view in **Figure 3**. The PHE consist of an arrangement of gasketed pressed metal plates (heat transfer surface), aligned on two carrying bars, secured between two cover by compression bolts. Inlet and outlet ports for both hot and cold fluids are stamped into the corners of each plate. The ports are lined up to form distribution headers through the plate pack.

All four fluid connection are usually located in the fixed and cover. This permits opening the exchanger without disconnecting any piping. Plates can be added and removes in the field should service requirements change. The plates are pressed into one of a number of available patterns and may be constructed of any material which can be cold formed to the desired pattern. The welding characteristics of the plate material are not prime importance since very little or no welding is involved in plate construction.

These design guideline are believed to be as accurate as possible, but are very general and not for specific design cases. They were designed for engineers to do preliminary designs and process specification sheets. The final design must always be guaranteed for the service selected by the manufacturing vendor, but these guidelines will greatly reduce the amount of up front engineering hours that are required to develop the final design. The guidelines are a training tool for young engineers or a resource for engineers with experience.

This document is entrusted to the recipient personally, but the copyright remains with us. It must not be copied, reproduced or in any way communicated or made accessible to third parties without our written consent.

KLM Technology Group Practical Engineering Guidelines for Processing Plant Solutions www.klmtechgroup.com	Kolmetz Handbook Of Process Equipment Design PLATE HEAT EXCHANGER SELECTION, SIZING AND TROUBLESHOOTING (ENGINEERING DESIGN GUIDELINES)	Page 14 of 97
		Rev: 02
		Rev 02 – Feb 2020

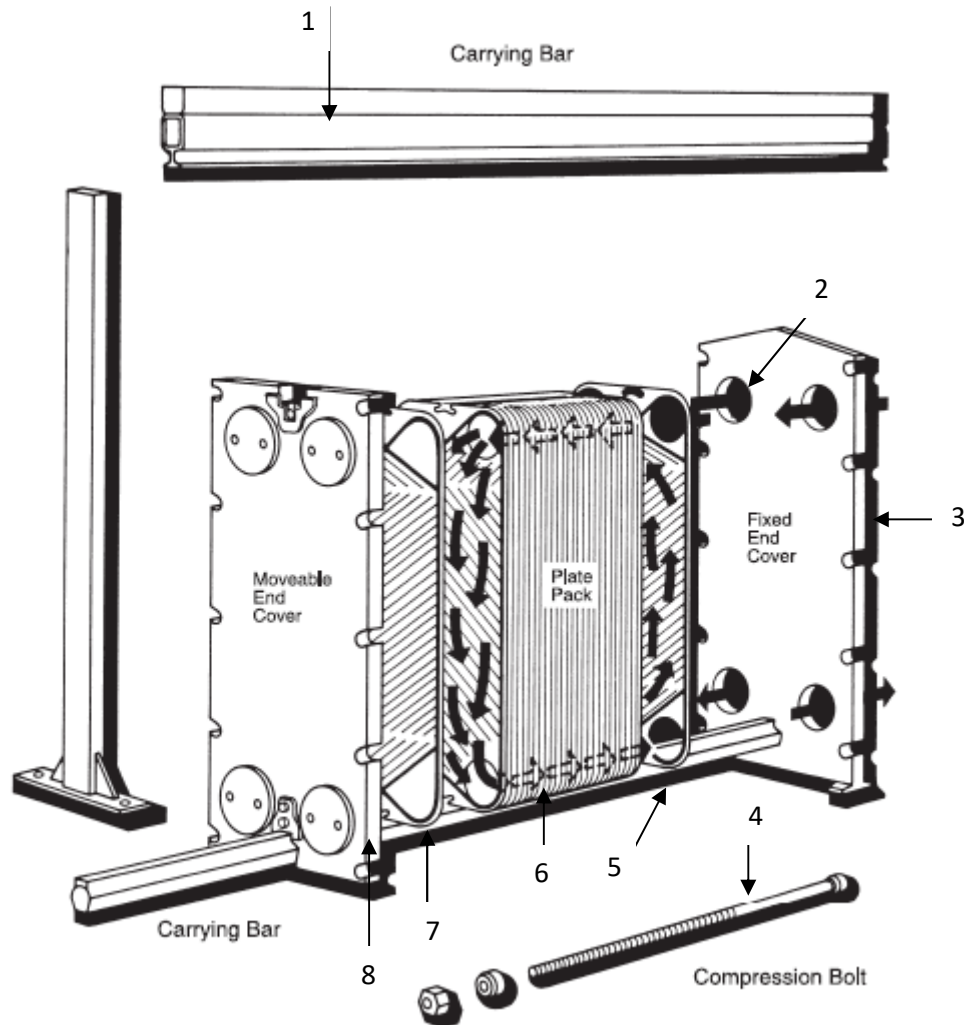

1. Carrying bar
2. Connections
3. Fixed frame
4. Tightening bolt
5. End plate with 4 holes
6. Channel plates with 4 holes
7. End plate with all 4 ports blind
8. Pressure plate

Figure 3. Plate and Frame Heat Exchanger

These design guideline are believed to be as accurate as possible, but are very general and not for specific design cases. They were designed for engineers to do preliminary designs and process specification sheets. The final design must always be guaranteed for the service selected by the manufacturing vendor, but these guidelines will greatly reduce the amount of up front engineering hours that are required to develop the final design. The guidelines are a training tool for young engineers or a resource for engineers with experience.

This document is entrusted to the recipient personally, but the copyright remains with us. It must not be copied, reproduced or in any way communicated or made accessible to third parties without our written consent.

KLM Technology Group Practical Engineering Guidelines for Processing Plant Solutions www.klmtechgroup.com	Kolmetz Handbook Of Process Equipment Design PLATE HEAT EXCHANGER SELECTION, SIZING AND TROUBLESHOOTING (ENGINEERING DESIGN GUIDELINES)	Page 15 of 97
		Rev: 02
		Rev 02 – Feb 2020

Gasket grooves are pressed into the plates as they are formed. The gaskets are generally made of elastomers such as natural rubber, nitrile, butyl, neoprene, etc. the gasket material chosen depends on the temperature, pressure, and chemical characteristics of the fluid to which it will be exposed. The gasket cross section varies with different plate designs and sizes. Rectangular, trapezoidal, or oval cross section are the most common. The width is generally 5-15 mm, depending on spacing.

The height of the gasket before it compressed is 15 to 50% higher than the spacing, depending on material, cross section of gasket, gasket track, and gasket hardness. When the plate stack is compressed, the exposed surface of the gasket is very small. The gasket are generally arranged in such a way that the through pass portal is sealed independently of the boundary gasket. Leaks from one fluid to the other cannot take place unless a plate develops a hole. Any leakage from the gaskets is to the outside of the exchanger where it is easily detected.

Since the plate are generally designed to form channels giving highly turbulent flow, the PHE produces higher heat transfer coefficients for liquid flow than most other types. The high heat transfer coefficients are developed through the efficient use pressure drop.

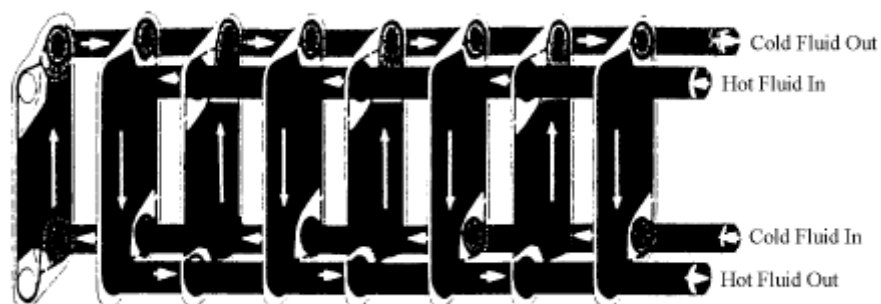

Figure 4. The Process and Service Fluid Flow Counter Currently Between The Plates

These design guideline are believed to be as accurate as possible, but are very general and not for specific design cases. They were designed for engineers to do preliminary designs and process specification sheets. The final design must always be guaranteed for the service selected by the manufacturing vendor, but these guidelines will greatly reduce the amount of up front engineering hours that are required to develop the final design. The guidelines are a training tool for young engineers or a resource for engineers with experience.

This document is entrusted to the recipient personally, but the copyright remains with us. It must not be copied, reproduced or in any way communicated or made accessible to third parties without our written consent.

KLM Technology Group Practical Engineering Guidelines for Processing Plant Solutions www.klmtechgroup.com	Kolmetz Handbook Of Process Equipment Design PLATE HEAT EXCHANGER SELECTION, SIZING AND TROUBLESHOOTING (ENGINEERING DESIGN GUIDELINES)	Page 16 of 97
		Rev: 02
		Rev 02 – Feb 2020

By means of gaskets, the two fluids can be arranged in countercurrent flow, and flow volumes can be divided into a number of parallel streams. Gaskets seal the plates at their outer edges and around the ports, which are designed so that the inlet port can be at the top or bottom. Gaskets provide a double seal between the liquid streams.

The interspace between the seals is vented to atmosphere, giving a visual indication of leakage and an escape path for the fluid.

Some of the possible flow patterns in plate exchangers are illustrated in **Figure 5.** : (a) series flow, in which a continuous stream changes direction after each vertical path; (b) parallel flow, in which the stream divides and then re-converges; (c) a loop system, in which both streams flow in parallel; (d) and (e) other complex flow patterns.

The number of parallel passages is mainly determined by the allowable pressure drop. Of course, the larger the number of parallel passages, the lower the pressure drop. The number of series passages is determined by plate efficiency and heat exchange requirements. If a liquid is cooled into viscous flow, the number of passages can be reduced to increase velocity.

These design guideline are believed to be as accurate as possible, but are very general and not for specific design cases. They were designed for engineers to do preliminary designs and process specification sheets. The final design must always be guaranteed for the service selected by the manufacturing vendor, but these guidelines will greatly reduce the amount of up front engineering hours that are required to develop the final design. The guidelines are a training tool for young engineers or a resource for engineers with experience.

This document is entrusted to the recipient personally, but the copyright remains with us. It must not be copied, reproduced or in any way communicated or made accessible to third parties without our written consent.

KLM Technology Group Practical Engineering Guidelines for Processing Plant Solutions www.klmtechgroup.com	Kolmetz Handbook Of Process Equipment Design	Page 17 of 97
	PLATE HEAT EXCHANGER SELECTION, SIZING AND TROUBLESHOOTING	Rev: 02
	(ENGINEERING DESIGN GUIDELINES)	Rev 02 – Feb 2020

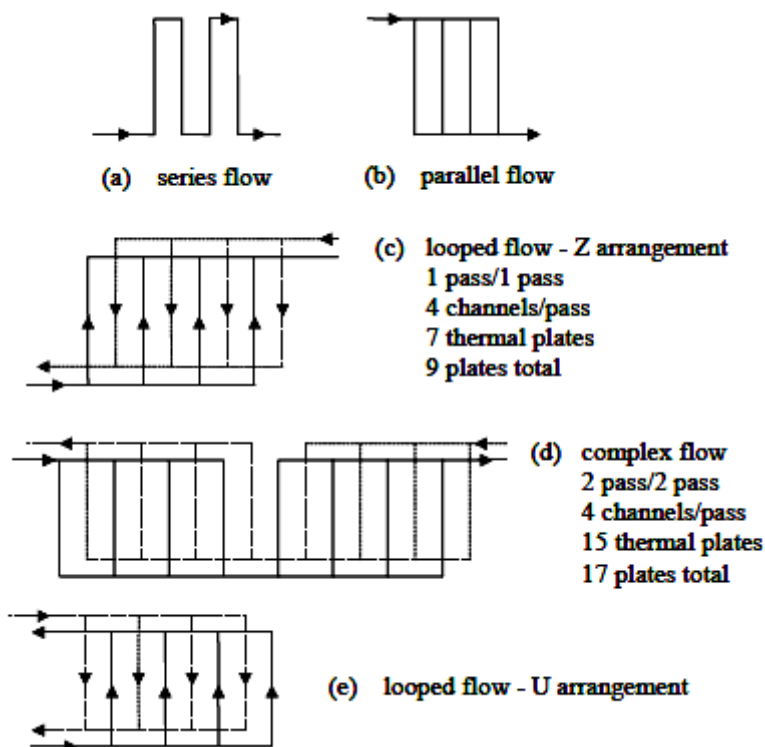

Figure 5. Double Gasketed Prevent Fluids Mixing

The advantages and disadvantages of gasketed plate heat exchangers, compared with conventional shell and tube exchangers are listed below :

Advantages

1. It can be easily be disassembled for cleaning.
2. The plates can be rearranged, added to, or removed from the plate rack for difference service conditions.
3. The fluid residence time is short (low fluid volume to surface area ratio).
4. No hot or cold spots exist which could damage temperature sensitive fluids.
5. Fluid leakage between streams cannot occur unless plate material fails.

These design guideline are believed to be as accurate as possible, but are very general and not for specific design cases. They were designed for engineers to do preliminary designs and process specification sheets. The final design must always be guaranteed for the service selected by the manufacturing vendor, but these guidelines will greatly reduce the amount of up front engineering hours that are required to develop the final design. The guidelines are a training tool for young engineers or a resource for engineers with experience.

This document is entrusted to the recipient personally, but the copyright remains with us. It must not be copied, reproduced or in any way communicated or made accessible to third parties without our written consent.

KLM Technology Group Practical Engineering Guidelines for Processing Plant Solutions www.klmtechgroup.com	Kolmetz Handbook Of Process Equipment Design PLATE HEAT EXCHANGER SELECTION, SIZING AND TROUBLESHOOTING (ENGINEERING DESIGN GUIDELINES)	Page 18 of 97
		Rev: 02
		Rev 02 – Feb 2020

6. Fluid package due to a defective or damaged gasket is external and easily detected.
7. Low fouling is encountered due to the high turbulence created by the plates.
8. A very small plot area is required relative to a shell and tube type heat exchanger for the same service.
9. The maintenance service area required is within the frame size of the exchanger.

Disadvantages

1. Care must be taken by maintenance personnel to prevent damage to the gaskets during disassembly, cleaning, and reassembly.
2. A relatively low upper design temperature limitation exists.
3. A relatively low upper design pressure limitation exists.
4. Gaskets materials are not compatible with all fluids.

These design guideline are believed to be as accurate as possible, but are very general and not for specific design cases. They were designed for engineers to do preliminary designs and process specification sheets. The final design must always be guaranteed for the service selected by the manufacturing vendor, but these guidelines will greatly reduce the amount of up front engineering hours that are required to develop the final design. The guidelines are a training tool for young engineers or a resource for engineers with experience.

This document is entrusted to the recipient personally, but the copyright remains with us. It must not be copied, reproduced or in any way communicated or made accessible to third parties without our written consent.

KLM Technology Group Practical Engineering Guidelines for Processing Plant Solutions www.klmtechgroup.com	Kolmetz Handbook Of Process Equipment Design PLATE HEAT EXCHANGER SELECTION, SIZING AND TROUBLESHOOTING (ENGINEERING DESIGN GUIDELINES)	Page 19 of 97
		Rev: 02
		Rev 02 – Feb 2020

Table 2. Typical Fouling Factors for PHEs

Fluid	Fouling Factor (m ² .h. °C/Kcal)
Water	
Determinalized or distilled	0.000002
Municipal supply (soft)	0.000004
Municipal supply (hard)	0.00001
Cooling tower (treated)	0.000008
Sea (coastal) or estuary	0.00001
Sea (ocean)	0.000006
River, canal, borehole, etc.	0.00001
Engine jacket	0.000012
Oils, lubricant	0.000004 to 0.00001
Solvents, organic	0.000002 to 0.000006
Steam	0.000002
Process fluids, general	0.000002 to 0.000012

These design guideline are believed to be as accurate as possible, but are very general and not for specific design cases. They were designed for engineers to do preliminary designs and process specification sheets. The final design must always be guaranteed for the service selected by the manufacturing vendor, but these guidelines will greatly reduce the amount of up front engineering hours that are required to develop the final design. The guidelines are a training tool for young engineers or a resource for engineers with experience.

This document is entrusted to the recipient personally, but the copyright remains with us. It must not be copied, reproduced or in any way communicated or made accessible to third parties without our written consent.

KLM Technology Group Practical Engineering Guidelines for Processing Plant Solutions www.klmtechgroup.com	Kolmetz Handbook Of Process Equipment Design PLATE HEAT EXCHANGER SELECTION, SIZING AND TROUBLESHOOTING (ENGINEERING DESIGN GUIDELINES)	Page 20 of 97
		Rev: 02
		Rev 02 – Feb 2020

Table 3. Comparison Between PHE and Shell and Tube Heat Exchanger (Mariott)

Features	Traditional PHE	Shell-Tube HE
Multiple duty	Possible	Impossible
Piping connections	From one direction (on frame plate)	From several directions
Heat-transfer ratio	3-5	1
Operating weight ratio	1	3-10
Hold-up volume	Low	High
Space ratio	1	2-5
Welds	None	Welded
Sensitivity to vibrations	Not sensitive	Sensitive
Gaskets	On every plate	On each flanged joint
Detection of leakage	Easy to detect on exterior	Difficult to detect
Access for inspection	On each side of plate	Limited
Time required for opening	15 min with pneumatic tightener	60-90 min
Repair	Easy to replace plate and/or gasket	Requires tube plugging (decreased capacity)
Modification	Easy by adding or removing plates	Impossible
Fouling	10-25% that of STHE	-

These design guideline are believed to be as accurate as possible, but are very general and not for specific design cases. They were designed for engineers to do preliminary designs and process specification sheets. The final design must always be guaranteed for the service selected by the manufacturing vendor, but these guidelines will greatly reduce the amount of up front engineering hours that are required to develop the final design. The guidelines are a training tool for young engineers or a resource for engineers with experience.

This document is entrusted to the recipient personally, but the copyright remains with us. It must not be copied, reproduced or in any way communicated or made accessible to third parties without our written consent.

KLM Technology Group Practical Engineering Guidelines for Processing Plant Solutions www.klmtechgroup.com	Kolmetz Handbook Of Process Equipment Design PLATE HEAT EXCHANGER SELECTION, SIZING AND TROUBLESHOOTING (ENGINEERING DESIGN GUIDELINES)	Page 21 of 97
		Rev: 02
		Rev 02 – Feb 2020

Plate Heat Exchanger Compare with Others

1. Superior thermal performance.

Plate heat exchangers are capable of nominal approach temperatures of 10°F compared to a nominal 20°F for shell and tube units. In addition, overall heat transfer coefficients (U) for plate type exchangers are three to four times those of shell and tube units.

2. Availability of a wide variety of corrosion resistant alloys.

Since the heat transfer area is constructed of thin plates, stainless steel or other high alloy construction is significantly less costly than for a shell and tube exchanger of similar material.

3. Ease of maintenance.

The construction of the heat exchanger is such that, upon disassembly, all heat transfer areas are available for inspection and cleaning. Disassembly consists only of loosening a small number of tie bolts.

4. Expandability and multiplex capability.

The nature of the plate heat exchanger construction permits expansion of the unit should heat transfer requirements increase after installation. In addition, two or more heat exchangers can be housed in a single frame, thus reducing space requirements and capital costs.

5. Compact design.

The superior thermal performance of the plate heat exchanger and the space efficient design of the plate arrangement results in a very compact piece of equipment. Space requirements for the plate heat exchanger generally run 10% to 50% that of a shell and

These design guideline are believed to be as accurate as possible, but are very general and not for specific design cases. They were designed for engineers to do preliminary designs and process specification sheets. The final design must always be guaranteed for the service selected by the manufacturing vendor, but these guidelines will greatly reduce the amount of up front engineering hours that are required to develop the final design. The guidelines are a training tool for young engineers or a resource for engineers with experience.

This document is entrusted to the recipient personally, but the copyright remains with us. It must not be copied, reproduced or in any way communicated or made accessible to third parties without our written consent.

KLM Technology Group Practical Engineering Guidelines for Processing Plant Solutions www.klmtechgroup.com	Kolmetz Handbook Of Process Equipment Design PLATE HEAT EXCHANGER SELECTION, SIZING AND TROUBLESHOOTING (ENGINEERING DESIGN GUIDELINES)	Page 22 of 97
		Rev: 02
		Rev 02 – Feb 2020

tube unit for equivalent duty. In addition, tube cleaning and replacing clearances are eliminated.

6. Low pressure/low temperature device

In comparison to shell and tube units, plate and frame heat exchangers are a relatively low pressure/low temperature device. Current maximum design ratings for most manufacturers are: temperature, 400oF, and 300 psig. Above these values, an alternate type of heat exchanger would have to be selected

7. Plate area

Individual plate area varies from about 0.3 to 21.5 ft² with a maximum heat transfer area for a single heat exchanger currently in the range of 13,000 ft². The minimum plate size does place a lower limit on applications of plate heat exchangers.

8. Overall heat transfer

Compared to shell-and-tube units, plate heat exchangers offer overall heat transfer coefficients 3 to 4 times higher. These values, typically 800 to 1200 Btu/- hr·ft² oF (clean), result in very compact equipment. This high performance also allows the specification of very small approach temperature (as low as 2 to 5oF)

Plate heat exchanger is universally used in many fields: heating and ventilating, breweries, dairy, food processing, pharmaceuticals and fine chemicals, petroleum and chemical industries, power generation, offshore oil and gas production, onboard ships, pulp and paper production, etc. Plate heat exchangers also find applications in water-to-water closed-circuit cooling-water systems using a potentially corrosive primary cooling water drawn from sea, river, lake, or cooling tower, to cool a clean, noncorrosive secondary liquid flowing in a closed circuit.

PHEs are not recommended for the following services:

These design guideline are believed to be as accurate as possible, but are very general and not for specific design cases. They were designed for engineers to do preliminary designs and process specification sheets. The final design must always be guaranteed for the service selected by the manufacturing vendor, but these guidelines will greatly reduce the amount of up front engineering hours that are required to develop the final design. The guidelines are a training tool for young engineers or a resource for engineers with experience.

This document is entrusted to the recipient personally, but the copyright remains with us. It must not be copied, reproduced or in any way communicated or made accessible to third parties without our written consent.

KLM Technology Group Practical Engineering Guidelines for Processing Plant Solutions www.klmtechgroup.com	Kolmetz Handbook Of Process Equipment Design PLATE HEAT EXCHANGER SELECTION, SIZING AND TROUBLESHOOTING (ENGINEERING DESIGN GUIDELINES)	Page 23 of 97
		Rev: 02
		Rev 02 – Feb 2020

- 1 Gas-to-gas applications.
- 2 Fluids with very high viscosity may pose flow distribution problems, particularly when cooling is taking place; flow velocities less than 0.1 m/s are not used because they give low heat-transfer coefficients and low heat exchanger efficiency.
- 3 Less suitable for vapors condensing under vacuum

limitations of plate heat exchangers include:

- 1 Upper plate size is limited by the available press capacity to stamp out the plates from the sheet metal.
- 2 Because of the narrow gap (or the flow passages) between the plates, high liquid rates will involve excessive pressure drops, thus limiting the capacity.
- 3 Frequent gasket removal (gaskets are numerous) during cleaning of plates can lower the gasket life.
- 4 Large differences in fluid flow rates of two streams cannot be handled.
- 5 Operation at lower pressures and temperatures due to the use of elastomer gaskets for sealing. Commonly stated limits have been 300°F (149°C) and 300 psi

These design guideline are believed to be as accurate as possible, but are very general and not for specific design cases. They were designed for engineers to do preliminary designs and process specification sheets. The final design must always be guaranteed for the service selected by the manufacturing vendor, but these guidelines will greatly reduce the amount of up front engineering hours that are required to develop the final design. The guidelines are a training tool for young engineers or a resource for engineers with experience.

This document is entrusted to the recipient personally, but the copyright remains with us. It must not be copied, reproduced or in any way communicated or made accessible to third parties without our written consent.

KLM Technology Group Practical Engineering Guidelines for Processing Plant Solutions www.klmtechgroup.com	Kolmetz Handbook Of Process Equipment Design PLATE HEAT EXCHANGER SELECTION, SIZING AND TROUBLESHOOTING (ENGINEERING DESIGN GUIDELINES)	Page 24 of 97
		Rev: 02
		Rev 02 – Feb 2020

DEFINITION

Brazing – is a metal joining process whereby a filler metal is heated above melting point and distribute between two or more close fitting parts by capillary action. The filler metal is brought slightly above its melting temperature while protected by a suitable atmosphere, usually a flux. It then flows over the base metal (known as wetting) and is then cooled to join the workpieces together. It is similar to soldering, except the temperatures used to melt the filler metal are higher for brazing.

Condensing – is the change of the physical state of matter from gas phase into liquid phase, and is the reverse of evaporation.

Evaporation – is a type of vaporization of a liquid that occurs from the surface of a liquid into a gaseous phase that is not saturated with the evaporating substance.

Fouling - The increased resistance to both heat transfer and fluid flow caused by deposits on a heat transfer surface. Fouling works as an insulating layer on the heat transfer surface, reducing heat transfer efficiency (reduced duty) or decreasing available flow area (reduced throughput). The increased resistance to heat transfer is represented by a quantity referred to as the fouling thermal resistance, which is added to the total thermal resistance. The values of fouling thermal resistance have generally been observed to increase with time. To account for the effect of fouling on pressure drop requires an estimate of the fouling layer thickness.

Furnace – is a device used for high temperature heating.

Gasket is a mechanical seal which fills the space between two or more mating surfaces, generally to prevent leakage from or into the joined objects while under compression.

Heater -A heater is any object that emits heat or causes another body to achieve a higher temperature. In a household or domestic setting, heaters are commonly used to generate heating

These design guideline are believed to be as accurate as possible, but are very general and not for specific design cases. They were designed for engineers to do preliminary designs and process specification sheets. The final design must always be guaranteed for the service selected by the manufacturing vendor, but these guidelines will greatly reduce the amount of up front engineering hours that are required to develop the final design. The guidelines are a training tool for young engineers or a resource for engineers with experience.

This document is entrusted to the recipient personally, but the copyright remains with us. It must not be copied, reproduced or in any way communicated or made accessible to third parties without our written consent.

KLM Technology Group Practical Engineering Guidelines for Processing Plant Solutions www.klmtechgroup.com	Kolmetz Handbook Of Process Equipment Design PLATE HEAT EXCHANGER SELECTION, SIZING AND TROUBLESHOOTING (ENGINEERING DESIGN GUIDELINES)	Page 25 of 97
		Rev: 02
		Rev 02 – Feb 2020

Pressure Drop – is defined as the difference in pressure between two points of a fluid carrying network. Pressure drop occurs when frictional forces, caused by resistance to flow, act on a fluid as it flows through the tube.

Superheater- is a device in a steam engine that heats the steam generated by the boiler again, increasing its thermal energy and decreasing the likelihood that it will condense inside the engine. Superheaters increase the efficiency of the steam engine, and were widely adopted. Steam which has been superheated is logically known as superheated steam; non-superheated steam is called saturated steam or wet steam. Superheaters were applied to steam locomotives in quantity from the early 20th century, to most steam vehicles, and to stationary steam engines including power stations.

Turbulence – is a flow regime characterized by chaotic property changes. This includes low momentum diffusion, high momentum convection, and rapid variation of pressure and flow velocity in space and time.

Welding – is a fabrication or sculptural process that joins materials, usually metals or thermoplastics, by causing coalescence.

These design guideline are believed to be as accurate as possible, but are very general and not for specific design cases. They were designed for engineers to do preliminary designs and process specification sheets. The final design must always be guaranteed for the service selected by the manufacturing vendor, but these guidelines will greatly reduce the amount of up front engineering hours that are required to develop the final design. The guidelines are a training tool for young engineers or a resource for engineers with experience.

This document is entrusted to the recipient personally, but the copyright remains with us. It must not be copied, reproduced or in any way communicated or made accessible to third parties without our written consent.

KLM Technology Group Practical Engineering Guidelines for Processing Plant Solutions www.klmtechgroup.com	Kolmetz Handbook Of Process Equipment Design PLATE HEAT EXCHANGER SELECTION, SIZING AND TROUBLESHOOTING (ENGINEERING DESIGN GUIDELINES)	Page 26 of 97
		Rev: 02
		Rev 02 – Feb 2020

NOMENCLATURE

a	= Plate thickness, mm
A	= area, (ft ²)
A/L	= Required heat transfer area per length (m ² /m)
A _f	= Fin area (m ²)
A _{ff}	= Free flow area (m ²)
A _{fr}	= Frontal area per fin (m ²)
A _o /A _w	= Total area/separating surface (wall) area
A _s	= Heat transfer Area (m ²)
b	= Plate spacing (mm)
C _{max}	= maximum heat capacity (W/K)
C _{min}	= minimum heat capacity (W/K)
C _p	= specific heat, (Btu/lb.°F)
D	= diameter, (in)
D _h	= Equivalent diameter (mm)
f	= Fin frequency, (fin/m)
<i>f</i>	= friction factor
F	= LMTD correction factor
F	= F factor
G	= mass velocity, (lb/ft ² .s)
H	= Convective Heat transfer Coefficient
H	= height, (in)
<i>h</i>	= specific enthalpy (J/kg)
H _c	= average heat transfer coefficient of cold fluid (W/m ² K)
H _h	= average heat transfer coefficient of hot fluid (W/m ² K)
J	= J factor
k	= thermal conductivity, (Btu/h.ft ² .°F)
l	= Fin length, (mm)
L	= length, (in)
LMTD	= Log Mean Temperature Difference, °F
ṁ	= mass flowrate, (lb/h)
M	= The fin parameter
<i>n</i>	= number constant
N	= number of exchangers
N _p	= number of passes

These design guideline are believed to be as accurate as possible, but are very general and not for specific design cases. They were designed for engineers to do preliminary designs and process specification sheets. The final design must always be guaranteed for the service selected by the manufacturing vendor, but these guidelines will greatly reduce the amount of up front engineering hours that are required to develop the final design. The guidelines are a training tool for young engineers or a resource for engineers with experience.

This document is entrusted to the recipient personally, but the copyright remains with us. It must not be copied, reproduced or in any way communicated or made accessible to third parties without our written consent.

KLM Technology Group Practical Engineering Guidelines for Processing Plant Solutions www.klmtechgroup.com	Kolmetz Handbook Of Process Equipment Design PLATE HEAT EXCHANGER SELECTION, SIZING AND TROUBLESHOOTING (ENGINEERING DESIGN GUIDELINES)	Page 27 of 97
		Rev: 02
		Rev 02 – Feb 2020

NTU	= number of heat transfer units
Nu	= nusselt number
P	= pressure, (lb/in ²)
p	= temperature efficiency
PHE	= plate and frame heat exchanger
Pr	= Prandtl number,
Q	= heat transferred, (Btu/h)
R	= heat capacity rate ratio
Re	= Reynolds number
s	= Fin spacing (mm)
t	= Fin thickness, (mm)
T	= temperature, (°F)
T _{avg}	= Average Bulk temperature (K)
T _{in}	= Inlet Temperature, (K)
T _m	= Mean film temperature (K)
T _{out}	= Outlet temperature, (K)
T _w	= Average wall temperature, (K)
U	= overall heat transfer coefficient, (Btu/h.ft ² . °F)
W	= width, (in)

Greek Letters

$\Delta p/L$	= Pressure drop per length
$1/UO$	= Overall thermal resistance (m ² K/W),
ΔP	= pressure drop, (lb/in ²)
η_f	= Fin effectiveness
η_o	= Overall efficiency,
μ	= viscosity, (centipoise)
ρ	= density
σ	= Frontal area ratio

These design guideline are believed to be as accurate as possible, but are very general and not for specific design cases. They were designed for engineers to do preliminary designs and process specification sheets. The final design must always be guaranteed for the service selected by the manufacturing vendor, but these guidelines will greatly reduce the amount of up front engineering hours that are required to develop the final design. The guidelines are a training tool for young engineers or a resource for engineers with experience.

This document is entrusted to the recipient personally, but the copyright remains with us. It must not be copied, reproduced or in any way communicated or made accessible to third parties without our written consent.