

KLM Technology Group Practical Engineering Guidelines for Processing Plant Solutions	 Engineering Solutions www.klmtechgroup.com	Page : 1 of 110
		Rev: 01
		Rev 01 - Nov 2014
KLM Technology Group P. O. Box 281 Bandar Johor Bahru, 80000 Johor Bahru, Johor, West Malaysia	Kolmetz Handbook of Process Equipment Design GAS PLANT SLUG CATCHER SELECTION, SIZING AND TROUBLESHOOTING (ENGINEERING DESIGN GUIDELINES)	Co Author: Rev 01 Reni Mutiara Sari
		Editor / Author Karl Kolmetz

TABLE OF CONTENT

INTRODUCTION

Scope	5
General Consideration	7
I. Two Phase Separator	7
A. Vapor-Liquid Separator	7
II. Three Phase Separator	10
A. Vapor-Liquid-Liquid Separator	10
III. Types of Slug Catcher	12
A. Vessel Type Slug Catcher	12
B. Multiple-pipe Slug Catchers	13
IV. Pigging	16
V. Liquid Hold-Up Volume	16
VI. Fluid Flow Regime	17

KLM Technology Group Practical Engineering Guidelines for Processing Plant Solutions www.klmtechgroup.com	Kolmetz Handbook Of Process Equipment Design GAS PLANT SLUG CATCHER SELECTION, SIZING AND TROUBLESHOOTING (ENGINEERING DESIGN GUIDELINES)	Page 2 of 110
		Rev: 01
		Nov 2014

DEFINITION	19
NOMENCLATURE	20
THEORY	22
I. Gravity Separation	22
II. Retention Time Method	25
A. Gas-Liquid Separation	25
B. Gas-Oil-Water Separation	26
III. Droplet Settling Method	26
IV. Slug Catcher Sizing	27
A. Two-phase Vapor- Liquid Separator Design	28
a. Vertical separator design procedure	29
b. Horizontal Separator Design Procedure	35
B. Three-Phase Vapor-Liquid-Liquid Separator Design	39
a. Vertical Three-Phase Separator Design Procedure	40
b. Horizontal Three-Phase Separator Design Procedure	44
i. Horizontal Separators Design with a Boot	45
ii. Horizontal Three-Phase Separators Design with Weir	48
C. Multiple-Pipe Slug Catcher Design Procedure	51

These design guideline are believed to be as accurate as possible, but are very general and not for specific design cases. They were designed for engineers to do preliminary designs and process specification sheets. The final design must always be guaranteed for the service selected by the manufacturing vendor, but these guidelines will greatly reduce the amount of up front engineering hours that are required to develop the final design. The guidelines are a training tool for young engineers or a resource for engineers with experience.

This document is entrusted to the recipient personally, but the copyright remains with us. It must not be copied, reproduced or in any way communicated or made accessible to third parties without our written consent.

KLM Technology Group Practical Engineering Guidelines for Processing Plant Solutions www.klmtechgroup.com	Kolmetz Handbook Of Process Equipment Design GAS PLANT SLUG CATCHER SELECTION, SIZING AND TROUBLESHOOTING (ENGINEERING DESIGN GUIDELINES)	Page 3 of 110
		Rev: 01
		Nov 2014

V. Instrumentation	51
APPLICATION	53
Example 1 : Two-Phase Vertical Separator sizing	53
Example 2 : Two-Phase Horizontal Separator sizing	59
Example 3 : Three-Phase Vertical Separator sizing	66
Example 4 : Three-Phase Horizontal Separator with a boot sizing	68
Example 5 : Three-Phase Horizontal Separator with a weir sizing	85
REFERENCES	96
LIST OF TABLES	
Table 1 : Liquid retention time for 2-phase separator	25
Table 2 : Typical retention time for 3-phase separator	26
Table 3 : Recommended K value	27
Table 4 : Separator K value	28
Table 5 : Liquid holdup and surge times	30
Table 6 : Low liquid level height	32
Table 7 : L/D ratio	35
Table 8 : Cylindrical height and area conversion	36
Table 9 : Wall thickness, surface area and approximate vessel weight	38

These design guideline are believed to be as accurate as possible, but are very general and not for specific design cases. They were designed for engineers to do preliminary designs and process specification sheets. The final design must always be guaranteed for the service selected by the manufacturing vendor, but these guidelines will greatly reduce the amount of up front engineering hours that are required to develop the final design. The guidelines are a training tool for young engineers or a resource for engineers with experience.

This document is entrusted to the recipient personally, but the copyright remains with us. It must not be copied, reproduced or in any way communicated or made accessible to third parties without our written consent.

KLM Technology Group Practical Engineering Guidelines for Processing Plant Solutions www.klmtechgroup.com	Kolmetz Handbook Of Process Equipment Design GAS PLANT SLUG CATCHER SELECTION, SIZING AND TROUBLESHOOTING (ENGINEERING DESIGN GUIDELINES)	Page 4 of 110
		Rev: 01
		Nov 2014

LIST OF FIGURES

Figure 1 : internal parts	8
Figure 2 : types of inlet diverter	10
Figure 3 : horizontal 3-phase separator	11
Figure 4 : vertical 3-phase separator	11
Figure 5 : vessel type slug catcher with separate surge drums	13
Figure 6 : multiple-pipe slug catcher	15
Figure 7 : pigging process	16
Figure 8 : multiphase flow regimes	17
Figure 9 : Drag coefficient for rigid spheres	23
Figure 10 : two-phase vertical separator	34
Figure 11 : two-phase horizontal separator	39
Figure 12 : determining the down comer allowable flow	42
Figure 13 : three-phase for vertical separator	44
Figure 14 : horizontal three-phase separators with a boot	46
Figure 15 : horizontal three-phase separators with a weir	50
Figure 16 : slug catcher control	52

These design guideline are believed to be as accurate as possible, but are very general and not for specific design cases. They were designed for engineers to do preliminary designs and process specification sheets. The final design must always be guaranteed for the service selected by the manufacturing vendor, but these guidelines will greatly reduce the amount of up front engineering hours that are required to develop the final design. The guidelines are a training tool for young engineers or a resource for engineers with experience.

This document is entrusted to the recipient personally, but the copyright remains with us. It must not be copied, reproduced or in any way communicated or made accessible to third parties without our written consent.

<p>KLM Technology Group</p> <p>Practical Engineering Guidelines for Processing Plant Solutions</p> <p>www.klmtechgroup.com</p>	<p>Kolmetz Handbook Of Process Equipment Design</p> <p>GAS PLANT SLUG CATCHER SELECTION, SIZING AND TROUBLESHOOTING</p> <p>(ENGINEERING DESIGN GUIDELINES)</p>	Page 5 of 110
		Rev: 01
		Nov 2014

INTRODUCTION

Scope

A multi-phase flow pipeline is intended for transporting the gas and liquid phases simultaneously from a production field to a processing unit. A gas plant slug catcher may be situated at the end of the pipeline to separate the phases and to provide temporary storage for the liquid received. There are different modes under which liquid can be produced from the pipeline. These include: the continuous liquid flow production mode under normal steady flow conditions; the intermittent or transient liquid production mode occurring when flow rates are varied; and the pigging or sphering mode when liquid is displaced from the pipeline into the slug catcher in a relatively short time.

These occasionally very large volumes of liquids encountered must be handled and stored as they emerge from the pipeline, preferably without any reduction in velocity, which would be reflected in the gas production. For this reason, a liquid-receiving facility known as a slug catcher is connected to a two phase pipeline^[9].

The initial gas-liquid separation occurs in a slug catcher. Slug catchers are critical because downstream gas processing units rely on a continuous gas stream free of liquids, even when surges of liquid enter the plant. A slug catcher is a gas-liquid separator sized to hold the biggest slug a plant will experience. Depending upon slug catcher design, inlet receiving handles just slugs or combines slug catching with liquid storage^[5].

The appropriate design of the slug catcher avoids problems at the receiving terminals. In order to prevent the acceleration of the gas/liquid mixture, the inlet diameter of the pipes entering the slug catcher should be the same as that of the pipeline. Normally the slug catcher is made up of a series of pipes that are parallel and inclined in order to give the hold-up volume for the liquid^[11].

Two steps to determine the slug catcher to be utilized are slug catcher selection and slug catcher sizing. Selection of slug catcher includes multiphase separator selection that based on function and liquid volume. The important of slug catcher hold-up volume and gas handling or terminal velocity are explained.

These design guideline are believed to be as accurate as possible, but are very general and not for specific design cases. They were designed for engineers to do preliminary designs and process specification sheets. The final design must always be guaranteed for the service selected by the manufacturing vendor, but these guidelines will greatly reduce the amount of up front engineering hours that are required to develop the final design. The guidelines are a training tool for young engineers or a resource for engineers with experience.

This document is entrusted to the recipient personally, but the copyright remains with us. It must not be copied, reproduced or in any way communicated or made accessible to third parties without our written consent.

<p>KLM Technology Group</p> <p>Practical Engineering Guidelines for Processing Plant Solutions</p> <p>www.klmtechgroup.com</p>	<p>Kolmetz Handbook Of Process Equipment Design</p> <p>GAS PLANT SLUG CATCHER SELECTION, SIZING AND TROUBLESHOOTING</p> <p>(ENGINEERING DESIGN GUIDELINES)</p>	Page 6 of 110
		Rev: 01
		Nov 2014

The theory for the slug catcher selection and sizing consists of gravity separation, two phase and three phase separators considerations. Multiple-pipe slug catcher design procedure and the instruments that typically installed in slug catcher are also summarized in this guideline.

INTRODUCTION

General Consideration

The slug catcher is mainly made up of two different compartments: the first one includes the multiphase separator under steady flow conditions while the second consists of the storage where the received liquid is accumulated under operating conditions. There are two and three phase separators which are described as follow.

I. Two Phase Separator

The slug catcher is a separator, where separation typically occurs between the heavy liquid hydrocarbons and the gaseous lighter ends i.e. the gas or vapor is separated from the liquids. The vapor – liquid separator is described as follow.

A. Vapor-Liquid Separator

Vapor-liquid separator is one of the most common types of process equipment in natural gas processing plants. A vapor-liquid separator is a vessel into which a liquid and vapor mixture is fed and wherein the liquid is separated by gravity, falls to the bottom of the vessel, and is withdrawn. The vapor travels upward at a design velocity which minimizes the entrainment of any liquid droplets in the vapor as it exits the top of the vessel.

A vapor-liquid separator might consist simply of an empty vessel, which causes the fluid velocities in the entering pipe to be reduced by enlarging the cross-sectional area of flow. Usually, however the separator includes internal parts, to promote separation of the process, such as ^[12]:

These design guideline are believed to be as accurate as possible, but are very general and not for specific design cases. They were designed for engineers to do preliminary designs and process specification sheets. The final design must always be guaranteed for the service selected by the manufacturing vendor, but these guidelines will greatly reduce the amount of up front engineering hours that are required to develop the final design. The guidelines are a training tool for young engineers or a resource for engineers with experience.

This document is entrusted to the recipient personally, but the copyright remains with us. It must not be copied, reproduced or in any way communicated or made accessible to third parties without our written consent.

<p>KLM Technology Group</p> <p>Practical Engineering Guidelines for Processing Plant Solutions</p> <p>www.klmtechgroup.com</p>	<p>Kolmetz Handbook Of Process Equipment Design</p> <p>GAS PLANT SLUG CATCHER SELECTION, SIZING AND TROUBLESHOOTING</p> <p>(ENGINEERING DESIGN GUIDELINES)</p>	Page 7 of 110
		Rev: 01
		Nov 2014

1. Primary separation section (entrance): for separating the bulk of the liquid from the gas. It is desirable to remove the liquid slugs and large droplets of liquid quickly from the gas stream, and to remove gas from the liquid.
2. Secondary separation section: for removing smaller particles of liquid by gravity settling depends to a large extent on the decreased gas velocity and reducing the turbulence of gas.
3. Liquid separation section (or the liquid accumulation section): for removing gas bubbles which may be occluded with the liquid, and for sufficient storage of the liquid to handle the slugs of liquid anticipated in routine operation.
4. Mist extractor or eliminator section (mist pad): for removing from the gas entrained drops of liquid, which did not separate in the secondary separation section. Mist extractor might be used to decrease the amount of entrained liquid in the gas and to reduce diameter of the vessel. Thickness of mist eliminator is typically 6 inch.
5. Vortex breaker (in the bottom of the vessel): prevents potential pump suction problems if a pump is used to remove collected liquids. Provide vortex breakers on outlet nozzles that are piped to a pump and where flow continuity at minimum liquid level is critical. Hydrocarbon liquid outlets should project 4 to 6 inches above the drum bottom if water is likely to be present and the water will interfere with downstream processing.

These design guideline are believed to be as accurate as possible, but are very general and not for specific design cases. They were designed for engineers to do preliminary designs and process specification sheets. The final design must always be guaranteed for the service selected by the manufacturing vendor, but these guidelines will greatly reduce the amount of up front engineering hours that are required to develop the final design. The guidelines are a training tool for young engineers or a resource for engineers with experience.

This document is entrusted to the recipient personally, but the copyright remains with us. It must not be copied, reproduced or in any way communicated or made accessible to third parties without our written consent.

<p>KLM Technology Group</p> <p>Practical Engineering Guidelines for Processing Plant Solutions</p> <p>www.klmtechgroup.com</p>	<p>Kolmetz Handbook Of Process Equipment Design</p> <p>GAS PLANT SLUG CATCHER SELECTION, SIZING AND TROUBLESHOOTING</p> <p>(ENGINEERING DESIGN GUIDELINES)</p>	Page 8 of 110
		Rev: 01
		Nov 2014

Separator vessel orientation may be vertical or horizontal. Vertical separators are most commonly used when the liquid-to-gas ratio is low or gas flow rates are low. They are preferred offshore because they occupy less platform area. Whereas, horizontal separators are favored for large liquid volumes or if the liquid-to-gas ratio is high. Lower gas flow rates and increased residence times offer better liquid dropout. The larger surface area provides better degassing and more stable liquid level as well^[5].

Following figures are two phase separators in vertical and horizontal.

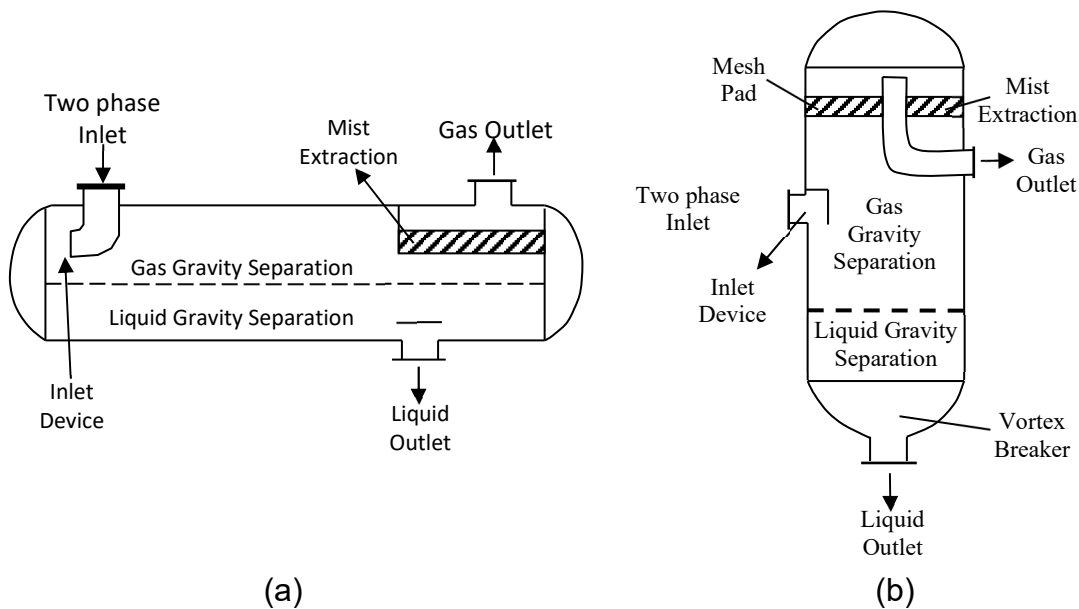

Figure 1: internal parts of (a) vertical separator and (b) horizontal separator

Separators may be designed with or without mist eliminator pads and may also have inlet diverters. Some separators may also have proprietary impingement or settling internals.

An inlet diverter produces the initial gross separation of liquid and vapor, as the sudden change in momentum occurs when the fluid enters the separator and hit it. Commonly,

These design guideline are believed to be as accurate as possible, but are very general and not for specific design cases. They were designed for engineers to do preliminary designs and process specification sheets. The final design must always be guaranteed for the service selected by the manufacturing vendor, but these guidelines will greatly reduce the amount of up front engineering hours that are required to develop the final design. The guidelines are a training tool for young engineers or a resource for engineers with experience.

This document is entrusted to the recipient personally, but the copyright remains with us. It must not be copied, reproduced or in any way communicated or made accessible to third parties without our written consent.

<p>KLM Technology Group</p> <p>Practical Engineering Guidelines for Processing Plant Solutions</p> <p>www.klmtechgroup.com</p>	<p>Kolmetz Handbook Of Process Equipment Design</p> <p>GAS PLANT SLUG CATCHER SELECTION, SIZING AND TROUBLESHOOTING</p> <p>(ENGINEERING DESIGN GUIDELINES)</p>	Page 9 of 110
		Rev: 01
		Nov 2014

the inlet diverter contains a down comer that directs the liquid flow below the oil or water interface. The inlet diverter assures that little gas is carried with the liquid. Some functions of inlet diverter are:

- Reduces momentum of inlet stream
- Provides primary (bulk) separation of gas and liquid
- Enhances flow distribution of gas and liquid phases
- Prevents droplet shattering and re-entrainment of bulk liquid phases
- Stable liquid level control and reduced foaming

Based on comparison of the performance of different inlet diverter in similar conditions, it states that a separator vessel would always be necessary to install a sophisticated inlet diverter such as vane type distributors or cyclones. The efficiency of their inlet diverters are 0.95 and more than 0.95 for bulk liquid removal^[13].

The impingement or settling internal might be added to optimized separation process. As the descriptive name suggests, the impingement separator allows the particle to be removed to strike some type of surfaces. There are basically three construction types for impingement separator: wire mesh, plates (curved, flat, or special shaped), and packed impingement beds.

II. Three Phase Separator

A. Vapor-Liquid-Liquid Separator

Three phase separation is commonly applied when there are water, liquid hydrocarbon and hydrocarbon gases in the process stream. As with two phase design, three phase units can be either vertical or horizontal.

Vertical vessel is mainly applied when there is a large amount of vapor to be separated from a small amount of the light and heavy fluid (less than 10-20% by weight). Horizontal vessels are most efficient where large volumes of total fluid and large amounts of dissolved gas are present with the liquid. An example for vertical vessels is the

These design guideline are believed to be as accurate as possible, but are very general and not for specific design cases. They were designed for engineers to do preliminary designs and process specification sheets. The final design must always be guaranteed for the service selected by the manufacturing vendor, but these guidelines will greatly reduce the amount of up front engineering hours that are required to develop the final design. The guidelines are a training tool for young engineers or a resource for engineers with experience.

This document is entrusted to the recipient personally, but the copyright remains with us. It must not be copied, reproduced or in any way communicated or made accessible to third parties without our written consent.

<p>KLM Technology Group</p> <p>Practical Engineering Guidelines for Processing Plant Solutions</p> <p>www.klmtechgroup.com</p>	<p>Kolmetz Handbook Of Process Equipment Design</p> <p>GAS PLANT SLUG CATCHER SELECTION, SIZING AND TROUBLESHOOTING</p> <p>(ENGINEERING DESIGN GUIDELINES)</p>	Page 10 of 110
		Rev: 01
		Nov 2014

compressor suction drums while good representative of horizontal vessel is the spent caustic de-oiling drum.

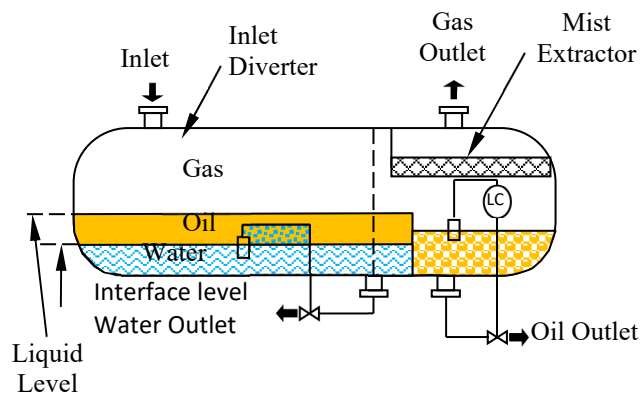

Figure 3: horizontal 3-phase separator

These design guideline are believed to be as accurate as possible, but are very general and not for specific design cases. They were designed for engineers to do preliminary designs and process specification sheets. The final design must always be guaranteed for the service selected by the manufacturing vendor, but these guidelines will greatly reduce the amount of up front engineering hours that are required to develop the final design. The guidelines are a training tool for young engineers or a resource for engineers with experience.

This document is entrusted to the recipient personally, but the copyright remains with us. It must not be copied, reproduced or in any way communicated or made accessible to third parties without our written consent.

<p>KLM Technology Group</p> <p>Practical Engineering Guidelines for Processing Plant Solutions</p> <p>www.klmtechgroup.com</p>	<p>Kolmetz Handbook Of Process Equipment Design</p> <p>GAS PLANT SLUG CATCHER SELECTION, SIZING AND TROUBLESHOOTING</p> <p>(ENGINEERING DESIGN GUIDELINES)</p>	Page 11 of 110
		Rev: 01
		Nov 2014

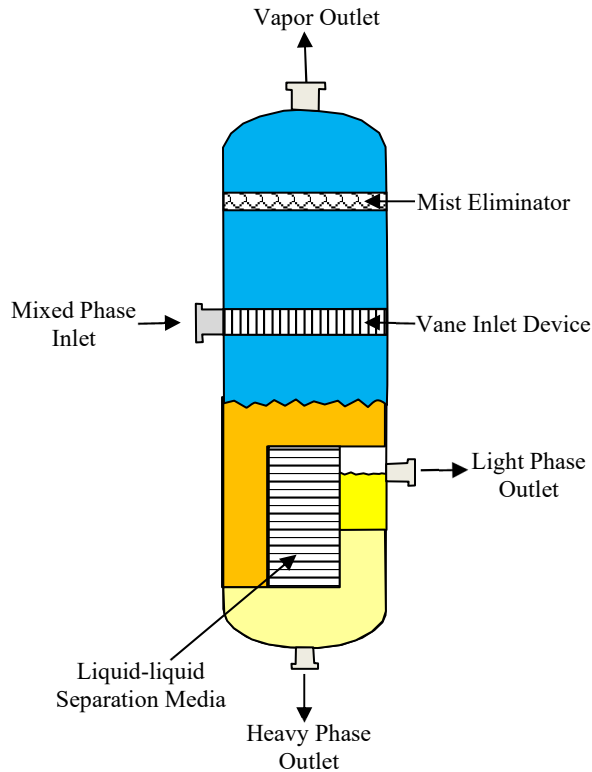

Figure 4: vertical 3-phase separator

The three phase separation vessel commonly contains four major sections as listed below:

- a. The primary separation section used to separate the main portion of free liquid in the inlet stream
- b. The secondary or gravity section designed to utilize the force of gravity to enhance separation of entrained droplets.

These design guideline are believed to be as accurate as possible, but are very general and not for specific design cases. They were designed for engineers to do preliminary designs and process specification sheets. The final design must always be guaranteed for the service selected by the manufacturing vendor, but these guidelines will greatly reduce the amount of up front engineering hours that are required to develop the final design. The guidelines are a training tool for young engineers or a resource for engineers with experience.

This document is entrusted to the recipient personally, but the copyright remains with us. It must not be copied, reproduced or in any way communicated or made accessible to third parties without our written consent.

<p>KLM Technology Group</p> <p>Practical Engineering Guidelines for Processing Plant Solutions</p> <p>www.klmtechgroup.com</p>	<p>Kolmetz Handbook Of Process Equipment Design</p> <p>GAS PLANT SLUG CATCHER SELECTION, SIZING AND TROUBLESHOOTING</p> <p>(ENGINEERING DESIGN GUIDELINES)</p>	Page 12 of 110
		Rev: 01
		Nov 2014

- c. The coalescing section utilizes a coalescer or mist extractor. The normal application is using a knitted wire mesh pad on top of vessel.
- d. The sump or liquid collection section acts as receiver for all liquid removed from gas in the primary, secondary, and coalescing section.

A vane-inlet device might be used in this separator to gradually reduce the inlet momentum and evenly distribute the gas phase across the vessel diameter. Such device can also act as the first-stage gas-liquid separation. In the gas-liquid portion of the vessel, a wire-mesh mist eliminator provides high separation efficiency.

For the liquid-liquid separation in the bottom of the drum, the first-stage is typically some type of enhanced-gravity separation media. If very high separation is required, adding a second “polishing” stage provides the ability to remove the last remnants of entrainment.

III. Types of Slug Catcher

There are basically two types of slug catchers, the vessel and multiple-pipe types that can be described as follow.

A. Vessel Type Slug Catcher

Vessel type slug catcher is simply gas-liquid separator that combine slug catching with liquid storage. They are usually employed where operating pressures are relatively low. The vessel type can range from a simple to a more complicated knock-out vessel which is mainly used for limited plot sizes such as offshore platforms due to its small size. This type is also normally used or crude-oil stream, where foaming sometimes emerges as a major problem.

These design guideline are believed to be as accurate as possible, but are very general and not for specific design cases. They were designed for engineers to do preliminary designs and process specification sheets. The final design must always be guaranteed for the service selected by the manufacturing vendor, but these guidelines will greatly reduce the amount of up front engineering hours that are required to develop the final design. The guidelines are a training tool for young engineers or a resource for engineers with experience.

This document is entrusted to the recipient personally, but the copyright remains with us. It must not be copied, reproduced or in any way communicated or made accessible to third parties without our written consent.

<p>KLM Technology Group</p> <p>Practical Engineering Guidelines for Processing Plant Solutions</p> <p>www.klmtechgroup.com</p>	<p>Kolmetz Handbook Of Process Equipment Design</p> <p>GAS PLANT SLUG CATCHER SELECTION, SIZING AND TROUBLESHOOTING</p> <p>(ENGINEERING DESIGN GUIDELINES)</p>	Page 13 of 110
		Rev: 01
		Nov 2014

The vessel type slug catcher is illustrated as shown in figure 5.

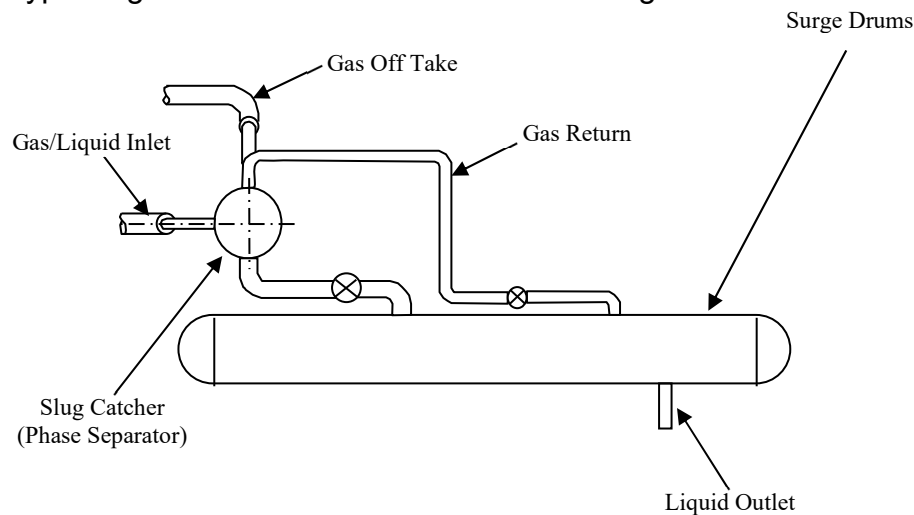

Figure 5 : vessel type slug catcher with separate surge drums

B. Multiple-pipe Slug Catchers

The multi-pipe slug catcher is made up of a liquid and gas separation entry slot and a series of parallel tilted bottles where the liquid is stored. However, this design requires special pigs to accommodate the change in line size. Multiple-pipe slug catchers have been widely applied in facilities processing a gas condensate stream. Multiple-pipe slug catcher is mainly used when liquid volume is larger than 100 m³[9]. The multiple-pipe slug catcher consist of several components^[11] :

a. Inlet section

In inlet section, gas-liquid of end of pipeline enters to inlet section to obtain an even distribution. To create such condition, the flow should be passing splitter and collected into inlet header before proceeding to the down comers. Down comers are inclined downward whenever possible to occur stratified two-phase flow and then flow to bottle section.

These design guideline are believed to be as accurate as possible, but are very general and not for specific design cases. They were designed for engineers to do preliminary designs and process specification sheets. The final design must always be guaranteed for the service selected by the manufacturing vendor, but these guidelines will greatly reduce the amount of up front engineering hours that are required to develop the final design. The guidelines are a training tool for young engineers or a resource for engineers with experience.

This document is entrusted to the recipient personally, but the copyright remains with us. It must not be copied, reproduced or in any way communicated or made accessible to third parties without our written consent.

<p>KLM Technology Group</p> <p>Practical Engineering Guidelines for Processing Plant Solutions</p> <p>www.klmtechgroup.com</p>	<p>Kolmetz Handbook Of Process Equipment Design</p> <p>GAS PLANT SLUG CATCHER SELECTION, SIZING AND TROUBLESHOOTING</p> <p>(ENGINEERING DESIGN GUIDELINES)</p>	Page 14 of 110
		Rev: 01
		Nov 2014

b. Bottle section

The bottle section of the slug catcher, including primary and/or secondary bottles. The primary bottles encompasses the gas-liquid separation just upstream the first gas risers. The storage of liquid takes place downstream the riser. The secondary bottles are designed to eliminate short inconsistencies in gas flow. They act as a gas reservoir and allow for co current gas and liquid flow in the system. Liquid from the primary bottles equalize into the secondary bottles where the displaced gas is free to flow into the process without restriction due to counter flow^[7]. This section also comprises a change in elevation between the gas risers and the storage section that allows a clear distinction between liquid and gas phases.

c. Gas outlet section

This section includes the gas risers, the gas outlet headers and the gas outlets. Ensuring a flow of gas out of the unit is the main function of a gas riser along with the prevention from liquid carryovers in case of large volumes of liquid passing through the lower region of the riser.

d. Liquid outlet section

For the liquid outlet, it should be of the same diameter as the bottles or minimum 75% of it in order to be able to handle the large liquid volumes without blocking the passage. The gas carry-under is to be taken care of or avoided by having the liquid outlet header lower than the lower end of the bottle^[11]. A schematic of this type appears in Figure 6.

These design guideline are believed to be as accurate as possible, but are very general and not for specific design cases. They were designed for engineers to do preliminary designs and process specification sheets. The final design must always be guaranteed for the service selected by the manufacturing vendor, but these guidelines will greatly reduce the amount of up front engineering hours that are required to develop the final design. The guidelines are a training tool for young engineers or a resource for engineers with experience.

This document is entrusted to the recipient personally, but the copyright remains with us. It must not be copied, reproduced or in any way communicated or made accessible to third parties without our written consent.

<p>KLM Technology Group</p> <p>Practical Engineering Guidelines for Processing Plant Solutions</p> <p>www.klmtechgroup.com</p>	<p>Kolmetz Handbook Of Process Equipment Design</p> <p>GAS PLANT SLUG CATCHER SELECTION, SIZING AND TROUBLESHOOTING</p> <p>(ENGINEERING DESIGN GUIDELINES)</p>	Page 15 of 110
		Rev: 01
		Nov 2014

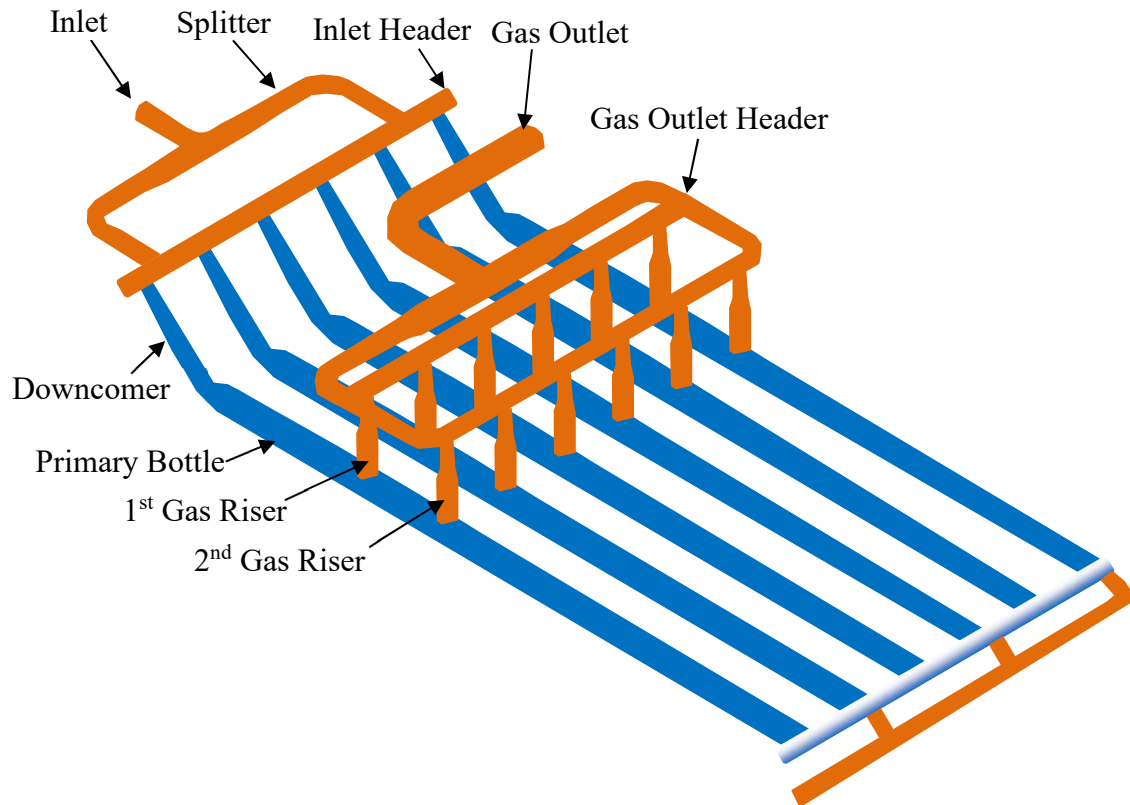

Figure 6: multiple-pipe slug catcher

In a slug catcher, the separation of liquid from the gas can occur in different manners, including:

1. Stratification in the inlet manifold, down comers and primary bottles
2. Droplet settling in the primary bottles
3. Deposition in bends and primary bottles
4. Tee-junction separation at entry into a gas riser^[9]

These design guideline are believed to be as accurate as possible, but are very general and not for specific design cases. They were designed for engineers to do preliminary designs and process specification sheets. The final design must always be guaranteed for the service selected by the manufacturing vendor, but these guidelines will greatly reduce the amount of up front engineering hours that are required to develop the final design. The guidelines are a training tool for young engineers or a resource for engineers with experience.

This document is entrusted to the recipient personally, but the copyright remains with us. It must not be copied, reproduced or in any way communicated or made accessible to third parties without our written consent.

<p>KLM Technology Group</p> <p>Practical Engineering Guidelines for Processing Plant Solutions</p> <p>www.klmtechgroup.com</p>	<p>Kolmetz Handbook Of Process Equipment Design</p> <p>GAS PLANT SLUG CATCHER SELECTION, SIZING AND TROUBLESHOOTING</p> <p>(ENGINEERING DESIGN GUIDELINES)</p>	Page 16 of 110
		Rev: 01
		Nov 2014

For inclined slug catchers, the goal is usually similar to provide the proper liquid hold-up volume, although the equations may be more complex depending on how steep the inclination is. If the slug catcher is mounted fairly steeply, the volume can be estimated by calculating the liquid holdup as a vertical vessel. If the inclination is gradual, the horizontal vessel calculation can be used for estimation purposes^[11].

IV. Pigging

Pigging is the process of forcing a solid object through a pipeline. The functions of pigging are provided in the lines to allow for pipeline cleaning and inspection, which are likely to be required during commissioning. In many instances pipelines are pigged to reduce pressure drop by lowering liquid hold-up volumes. In addition, it is also beneficial for reducing slug catcher size and reducing corrosion from any free water and other contaminants in the line.

Launching a pig into the system will remove the majority of liquid and will end up in the slug catcher at the receiving facilities. Pigging can affect greatly the regularity of the slug emergence to the slug catcher aside from the natural slug flow. The design basis for pigging frequency will have a significant impact on slug sizes from pigging and the required slug catcher size. Process of pigging can be shown in figure 7.

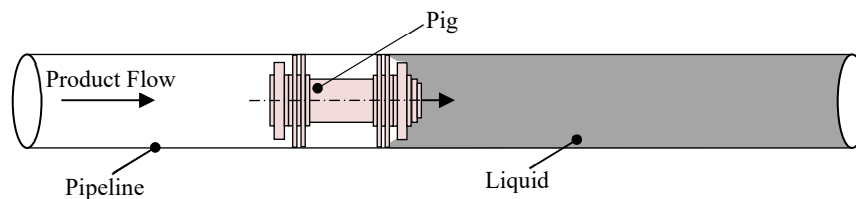

Figure 7: pigging process

V. Liquid Hold-Up Volume

The liquid hold up calculation is very often the key element in sizing slug catcher facilities. If frequent pigging is not used on the line, and the pipeline is allowed to achieve steady state operation in regard to liquid hold up, the slug volume expected should be estimated as the liquid hold up of the entire pipeline. For long pipelines (longer than 5 miles), the liquid hold-up calculation and bypass pig will be important in determining if

These design guideline are believed to be as accurate as possible, but are very general and not for specific design cases. They were designed for engineers to do preliminary designs and process specification sheets. The final design must always be guaranteed for the service selected by the manufacturing vendor, but these guidelines will greatly reduce the amount of up front engineering hours that are required to develop the final design. The guidelines are a training tool for young engineers or a resource for engineers with experience.

This document is entrusted to the recipient personally, but the copyright remains with us. It must not be copied, reproduced or in any way communicated or made accessible to third parties without our written consent.

<p>KLM Technology Group</p> <p>Practical Engineering Guidelines for Processing Plant Solutions</p> <p>www.klmtechgroup.com</p>	<p>Kolmetz Handbook Of Process Equipment Design</p> <p>GAS PLANT SLUG CATCHER SELECTION, SIZING AND TROUBLESHOOTING</p> <p>(ENGINEERING DESIGN GUIDELINES)</p>	Page 17 of 110
		Rev: 01
		Nov 2014

frequent pigs should be run in the pipe to avoid having large slug volumes. In most cases with a shorter pipeline, the slug catcher should be sized for at least the liquid hold-up in the pipeline.

To reduce liquid hold up requirements in the slug catcher, it may be advantageous to install an intermediate vessel (e.g. condensate feed drum) for additional liquid surge capacity. The intermediate vessel typically operates at a lower pressure than the slug catcher and it therefore reduces the cost of liquid slug volume capacity. The offset to this cost savings is the flash gas handling equipment such as a separate flash gas compressor^[11].

VI. Fluid Flow Regime

Several multiphase flow regimes take place in horizontal pipelines. Phase separation usually occurs when the gravity effect is perpendicular to the pipe axis. Operating in these flow regimes also will help minimize pigging frequency and slug catcher capacity requirements. There are seven flow regimes that represented as shown in figure 8.

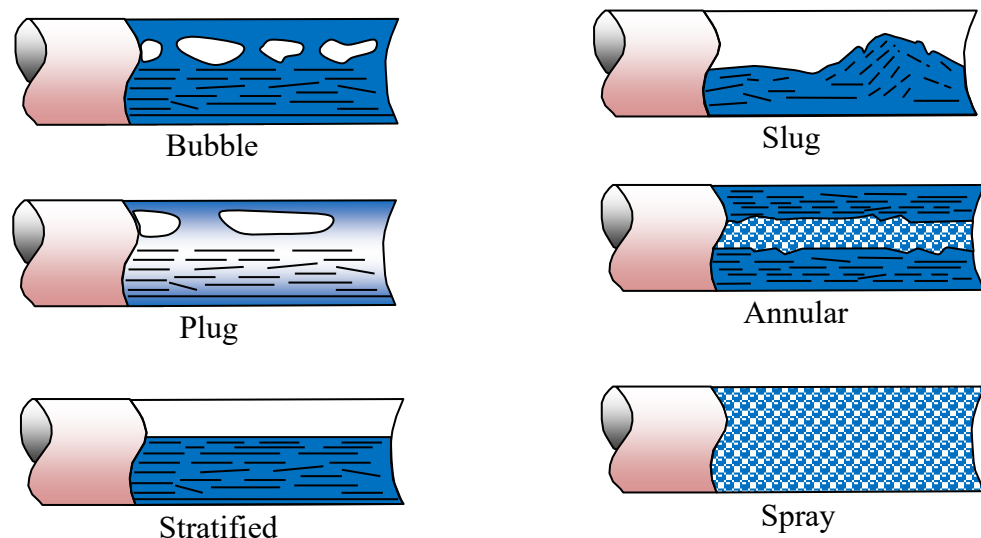

Figure 8: multiphase flow regimes

These design guideline are believed to be as accurate as possible, but are very general and not for specific design cases. They were designed for engineers to do preliminary designs and process specification sheets. The final design must always be guaranteed for the service selected by the manufacturing vendor, but these guidelines will greatly reduce the amount of up front engineering hours that are required to develop the final design. The guidelines are a training tool for young engineers or a resource for engineers with experience.

This document is entrusted to the recipient personally, but the copyright remains with us. It must not be copied, reproduced or in any way communicated or made accessible to third parties without our written consent.

KLM Technology Group Practical Engineering Guidelines for Processing Plant Solutions www.klmtechgroup.com	Kolmetz Handbook Of Process Equipment Design GAS PLANT SLUG CATCHER SELECTION, SIZING AND TROUBLESHOOTING (ENGINEERING DESIGN GUIDELINES)	Page 18 of 110
		Rev: 01
		Nov 2014

The types of flow regimes can be described as the vapor rate increases as follow^[1] :

1. Bubble flow : bubbles dispersed in liquid with vapor and liquid velocities are approximately equal.
2. Plug flow : plugs of liquid flow followed by plugs of gas. The bubbles coalesce, and alternating plugs of vapor and liquid flow along the top of the pipe with liquid remaining the continuous phase along the bottom.
3. Stratified flow : liquid and gas flow in stratified layers. The fraction occupied by each phase remains constant.
4. Wavy flow : gas flows in top of pipe section, liquid in lower section and the resulting friction at the interface forms liquid waves.
5. Slug flow : slugs of gas bubbles flowing through the liquid. It is formed when the liquid waves grow large enough to bridge the entire pipe diameter and the stratified flow pattern breaks down.
6. Annular flow : liquid flows in continuous annular ring on pipe wall, gas flows through center of pipe.
7. Spray flow : gas and liquid dispersed. When the vapor velocity in annular flow becomes high enough, all of the liquid film is torn away from the wall and is carried by the vapor as entrained droplets.

These design guideline are believed to be as accurate as possible, but are very general and not for specific design cases. They were designed for engineers to do preliminary designs and process specification sheets. The final design must always be guaranteed for the service selected by the manufacturing vendor, but these guidelines will greatly reduce the amount of up front engineering hours that are required to develop the final design. The guidelines are a training tool for young engineers or a resource for engineers with experience.

This document is entrusted to the recipient personally, but the copyright remains with us. It must not be copied, reproduced or in any way communicated or made accessible to third parties without our written consent.

<p style="text-align: center;">KLM Technology Group</p> <p style="text-align: center;">Practical Engineering Guidelines for Processing Plant Solutions</p> <p style="text-align: center;">www.klmtechgroup.com</p>	<p>Kolmetz Handbook Of Process Equipment Design</p> <p>GAS PLANT SLUG CATCHER SELECTION, SIZING AND TROUBLESHOOTING</p> <p>(ENGINEERING DESIGN GUIDELINES)</p>	Page 19 of 110
		Rev: 01
		Nov 2014

DEFINITION

Accumulators- These are storage tanks following distillation column condensers. For partial condensers, this flow may be a mixture of vapor and liquid. The outlet flow may be regulated by a level controller in order to avoid the tank either flooding (liquid out the top) or going dry (vapor out the bottom).

Coalescer - A mechanical process vessel with wettable, high-surface area packing on which liquid droplets consolidate for gravity separation from a second phase (for example gas or immiscible liquid).

Demister Mist Extractor- A device installed in the top of scrubbers, separators, tray or packed vessels, etc. to remove liquid droplets entrained in a flowing gas stream.

Disengaging Height- The height provided between bottom of the wire-mesh pad and liquid level of a vapor-liquid separator.

Hold-Up Time- A time period during which the amount of liquid separated in a gas-liquid separator is actually in the vessel for the purpose of control or vapor separation.

Knock-Out- A separator used for a bulk separation of gas and liquid.

Line Drip- A device typically used in pipelines with very high gas-to-liquid ratios to remove only free liquid from a gas stream, and not necessarily all the liquid.

Manifold - A pipe with one or more inlets and two or more outlets, or vice versa.

Mesh- The "mesh count" (usually called "mesh"), is effectively the number of openings of a woven wire filter per 25 mm, measured linearly from the center of one wire to another 25 mm from it.

Pigging - Procedure of forcing a solid object through a pipeline for cleaning or other purposes.

Residence time - The time period for which a fluid will be contained within a specified volume.

These design guideline are believed to be as accurate as possible, but are very general and not for specific design cases. They were designed for engineers to do preliminary designs and process specification sheets. The final design must always be guaranteed for the service selected by the manufacturing vendor, but these guidelines will greatly reduce the amount of up front engineering hours that are required to develop the final design. The guidelines are a training tool for young engineers or a resource for engineers with experience.

This document is entrusted to the recipient personally, but the copyright remains with us. It must not be copied, reproduced or in any way communicated or made accessible to third parties without our written consent.

<p style="text-align: center;">KLM Technology Group</p> <p style="text-align: center;">Practical Engineering Guidelines for Processing Plant Solutions</p> <p style="text-align: center;">www.klmtechgroup.com</p>	<p>Kolmetz Handbook Of Process Equipment Design</p> <p>GAS PLANT SLUG CATCHER SELECTION, SIZING AND TROUBLESHOOTING</p> <p>(ENGINEERING DESIGN GUIDELINES)</p>	Page 20 of 110
		Rev: 01
		Nov 2014

Slug catcher - Separator that is designed to separate intermittent large volumes of liquids from a gas stream.

Surge time - The time it takes for the liquid level to rise from normal (NLL) to maximum (HLL) while maintaining a normal feed without any outlet flow.

Terminal Velocity or Drop-Out Velocity- The velocity at which a particle or droplet will fall under the action of gravity, when drag force just balances gravitational force and the particle (or droplet) continues to fall at constant velocity.

Underflow - The stream containing the remaining liquid and the coarser solids, which is discharged through a circular opening at the apex of the core of a hydrocyclone is referred to as "underflow".

Vapor Space- The volume of a vapor liquid separator above the liquid level.

NOMENCLATURE

A_D	= downcomer cross-sectional area, ft ²
A_{NLL}	= normal and high liquid level, ft ²
A_{LL}	= the cross-sectional area of the light liquid, ft ²
A_V	= vapor disengagement area, ft ²
C'	= drag coefficient, dimensionless
D	= vessel diameter, ft or in
D_B	= heavy liquid boot diameter, ft
d_N	= nozzle diameter, ft
D_p	= droplet diameter, ft or microns
D_{VD}	= vapor disengagement diameter, ft
g	= gravitational constant, ft/s ²
H_A	= liquid level above baffle, which is 6 inch (minimum)
H_{BN}	= liquid height from above baffle to feed nozzle, ft
H_D	= disengagement height, ft
H_H	= holdup height, ft
H_{LL}	= high liquid level height, ft
H_{LLL}	= low liquid level height, ft

These design guideline are believed to be as accurate as possible, but are very general and not for specific design cases. They were designed for engineers to do preliminary designs and process specification sheets. The final design must always be guaranteed for the service selected by the manufacturing vendor, but these guidelines will greatly reduce the amount of up front engineering hours that are required to develop the final design. The guidelines are a training tool for young engineers or a resource for engineers with experience.

This document is entrusted to the recipient personally, but the copyright remains with us. It must not be copied, reproduced or in any way communicated or made accessible to third parties without our written consent.

<p>KLM Technology Group</p> <p>Practical Engineering Guidelines for Processing Plant Solutions</p> <p>www.klmtechgroup.com</p>	<p>Kolmetz Handbook Of Process Equipment Design</p> <p>GAS PLANT SLUG CATCHER SELECTION, SIZING AND TROUBLESHOOTING</p> <p>(ENGINEERING DESIGN GUIDELINES)</p>	Page 21 of 110
		Rev: 01
		Nov 2014

H_R	= height from light liquid nozzle to baffle, in
H_s	= surge height, ft
H_T	= total height, ft
H_v	= minimum height of the vapor disengagement area, ft
H_w	= weir height, ft
L	= minimum length to accommodate the liquid holdup/surge, ft
L_{min}	= length required for vapor-liquid disengagement, ft
M	= fraction of vertical area filled with liquid, dimensionless
Q_{HL}	= heavy liquid volumetric flow rate, ft ³ /min
Q_m	= Mixture volumetric flow rate, ft ³ /s
Q_L	= liquid volumetric flow rate, ft ³ /min
Q_{LL}	= light liquid volumetric flow rate, ft ³ /min
Q_V	= vapor volumetric flow rate, ft ³ /s
Re	= reynold number, dimensionless
t_{HL}	= settling time for the heavy liquid droplets, min
t_{LL}	= settling time for the light liquid droplets, min
T_H	= holdup times, min
T_s	= surge times, min
V_H	= holdup volume, ft
V_s	= surge volume, ft
V_T	= terminal velocity, ft/s or in/min
V_{VA}	= actual vapor velocity, ft/s

These design guideline are believed to be as accurate as possible, but are very general and not for specific design cases. They were designed for engineers to do preliminary designs and process specification sheets. The final design must always be guaranteed for the service selected by the manufacturing vendor, but these guidelines will greatly reduce the amount of up front engineering hours that are required to develop the final design. The guidelines are a training tool for young engineers or a resource for engineers with experience.

This document is entrusted to the recipient personally, but the copyright remains with us. It must not be copied, reproduced or in any way communicated or made accessible to third parties without our written consent.

<p style="text-align: center;">KLM Technology Group</p> <p style="text-align: center;">Practical Engineering Guidelines for Processing Plant Solutions</p> <p style="text-align: center;">www.klmtechgroup.com</p>	<p>Kolmetz Handbook Of Process Equipment Design</p> <p>GAS PLANT SLUG CATCHER SELECTION, SIZING AND TROUBLESHOOTING</p> <p>(ENGINEERING DESIGN GUIDELINES)</p>	Page 22 of 110
		Rev: 01
		Nov 2014

Greek Letter

- λ = Mixture liquid fraction
- \dot{m}_L = mass flow rate of liquid, lb/h
- \dot{m}_{LL} = light liquid mass flow rate, lb/h
- \dot{m}_{HL} = heavy liquid mass flow rate, lb/h
- \dot{m}_V = mass flow rate of vapor, lb/h
- ρ_m = Mixture density, lb/ft³
- ρ_{HL} = heavy liquid density, lb/ft³
- ρ_L = liquid density, lb/ft³
- ρ_{LL} = light liquid density, lb/ft³
- ρ_V = vapor density, lb/ft³
- Φ = liquid drop time, s
- θ_{HL} = residence time of heavy liquid phase, min
- θ_{LL} = residence time of light liquid phase, min

These design guideline are believed to be as accurate as possible, but are very general and not for specific design cases. They were designed for engineers to do preliminary designs and process specification sheets. The final design must always be guaranteed for the service selected by the manufacturing vendor, but these guidelines will greatly reduce the amount of up front engineering hours that are required to develop the final design. The guidelines are a training tool for young engineers or a resource for engineers with experience.

This document is entrusted to the recipient personally, but the copyright remains with us. It must not be copied, reproduced or in any way communicated or made accessible to third parties without our written consent.